

Peristaltic Pump
Laboratorial Syringe Pump
Industrial Syringe Pump
Micro Gear Pump
Piston Pump
Pump System
OEM

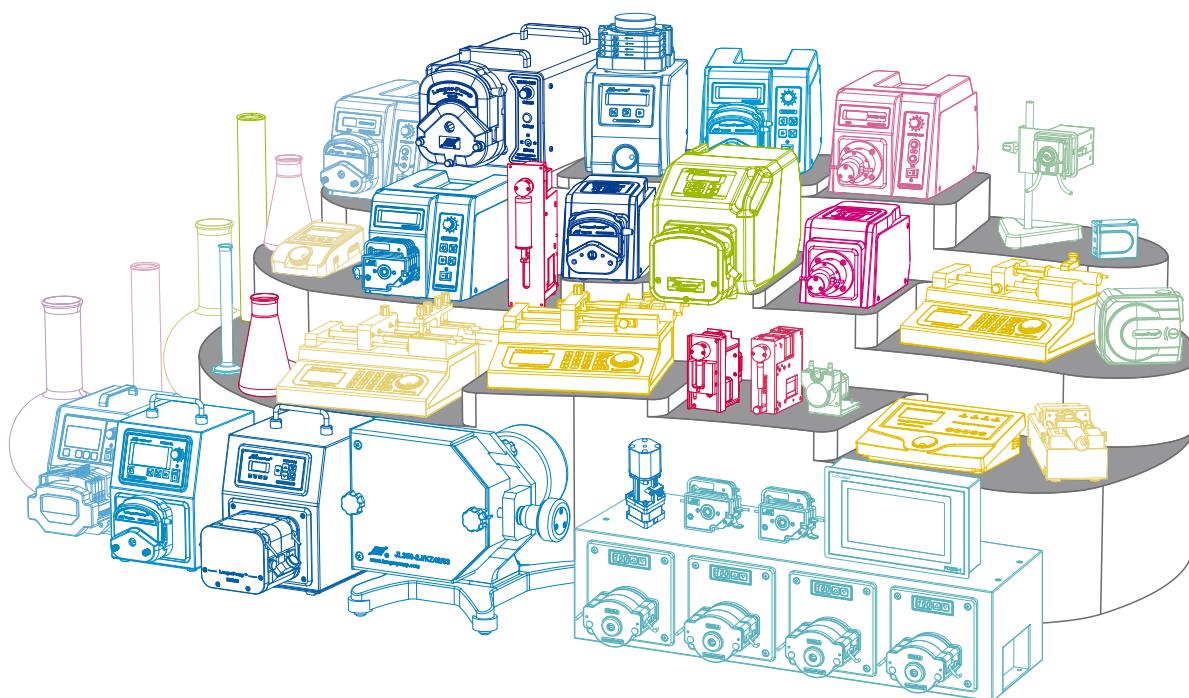

Longer Precision Pump Co., Ltd.

 www.longerpump.com

2025 / 2026

About Us

Longer Precision Pump Co., Ltd, was founded in 1997, and is a wholly owned subsidiary of the Halma Group. It is affiliated to the Healthcare Sector and specializes in R&D, production and the sale of precise fluid transfer and handling devices.

Longer has always been focussed on the customer's requirements, and we provide our customers with safe, high accuracy and quality fluid transfer devices and solutions. Our products include peristaltic pumps, laboratorial syringe pumps, industrial syringe pumps, micro-gear pumps, dispensing and filling systems, etc., which can also be customized and designed to OEM pumps according to the clients' different needs. Longer has more than 40 series of products with over 600 specifications. We are hyper-focused on the quality, delivery, value and technology of products and services, and provide products and services for the Pharmaceutical, Medical, Environmental monitoring and Laboratory fields, etc.

All of our products are produced with the most advanced manufacturing equipment and testing devices under the assurance of ISO9001:2015. Additionally, we have set up Research Centres in Baoding and Shanghai with branches in the United States. We serve customers in more than 130 countries and territories through diversified marketing channels.

Halma is a global group of life-saving technology companies. Named as one of Britain's Most Admired Companies, with a group of 45 companies providing innovative products and services that help solve many of the key problems facing the world today.

Halma employs over 7,000 people in more than 20 countries, with major operations in the UK, Mainland Europe, the USA and Asia Pacific. Halma is listed on the London Stock Exchange and is a constituent of the FTSE 100.

Halma's purpose is to grow a safer, cleaner, healthier future for everyone, every day.



Enterprise Intellectual Property



CE Safety Certificate



Product Qualification Certificate

Peristaltic Pump Configuration

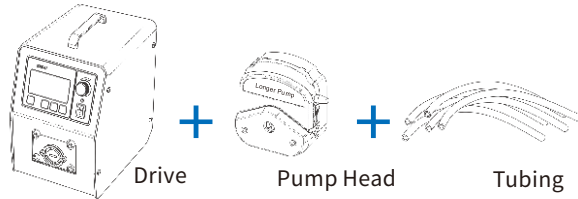

Peristaltic Pump Features

Non-contamination, easy to clean, low shear, simple maintenance

Peristaltic Pump Working Principle

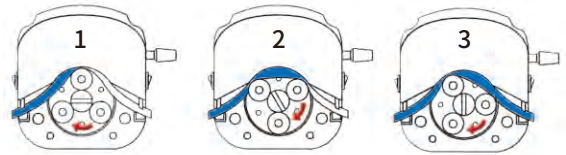

Laboratorial Syringe Pump Configuration

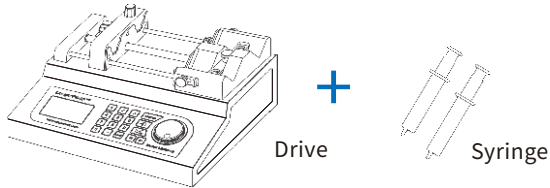

Laboratorial Syringe Pump Features

High accuracy, diversity, laboratory use only

Laboratorial Syringe Pump Working Principle

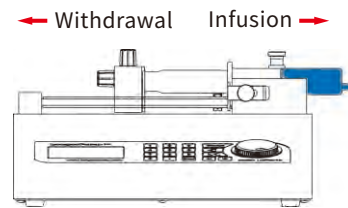

Industrial Syringe Pump Configuration

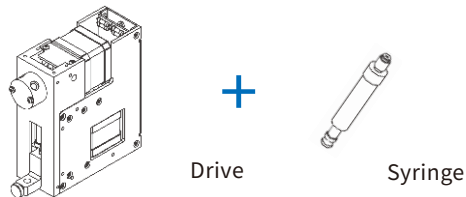

Industrial Syringe Pump Features

Intelligent, high accuracy, embedded installation and OEM use only

Industrial Syringe Pump Working Principle

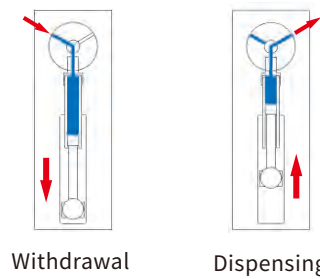

Gear Pump Configuration

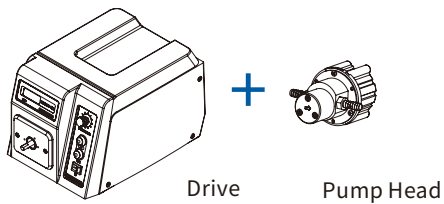

Gear Pump Features

Low pulse constant flow rate, higher pressure than peristaltic pump

Gear Pump Working Principle

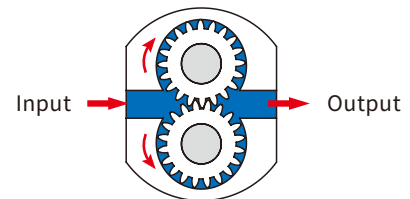

Piston Pump Configuration

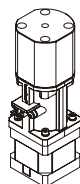

Piston Pump Features

High accuracy, compact size, Non-Wearing and long life

Piston Pump Working Principle

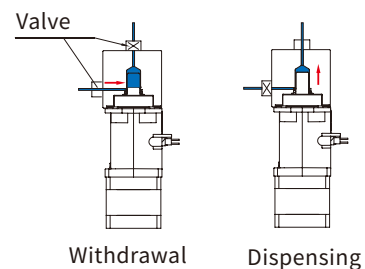

Table of Contents

Biosicon®Silicone Tubing		01
Peristaltic Pump Head	Max. Flow Rate(Single Channel)	02-12
Intelligent Peristaltic Pump		14
L100-1F, L100-1FS,L300-1F, L300-1FS, L600-1F,L600-1FS	3000mL/min	14
Mini Series Peristaltic Pump		15-17
CM100-2A&WX10	40mL/min	15
CM200-1A,CM200-2A,CM400-1A,CM400-2A	340mL/min	16
CM200-2B,CM400-2B	1520mL/min	17
Basic Peristaltic Pump		18-24
BT100-3J	380mL/min	18
BT300-2J , BT600-2J	3000mL/min	19
WT600-2J	6000mL/min	20
WT600-3J	6000mL/min	21
YT600-1J	11000mL/min	22
JL350-2J	35L/min	23
BQ50-1J	20mL/min	24
Standard Peristaltic Pump		25
L100-1S-2	500mL/min	25
Flow Rate Peristaltic Pump		26-27
LEAD-2	300mL/min	26
BT100-1L	500mL/min	27
Dispensing Peristaltic Pump		28-31
BT100-1F	500mL/min	28
BT300-1F	1500mL/min	29
WT600-1F	6000mL/min	30
WT600-4F	11000mL/min	31
Industrial Peristaltic Pump		32
G100-1L,G300-1L,G600-1L	3250mL/min	32
dPOFLEX®Industrial Peristaltic Pump		33-34
dPOFLEX® GP01,BP01	17L/min	33
dPOFLEX® GP02,BP02	9L/min	34
dPOFLEX®Explosion Proof Motor Pump		35-36
dPOFLEX® EP01	17L/min	35
dPOFLEX® EP02,EP02-B	6000mL/min	36
dLSP 501X Series Digital Split-type Syringe Pump		38
dLSP 501S,dLSP 501L,dLSP 501W	95.82mL/min	38
Laboratorial Syringe Pump		39-44
dLSP 500 series	120.044mL/min	39
ASP100 Series Digital Syringe Pump	226.0mL/min	40
LSP04-1A	28.135mL/min	41
LSP10-1B	28.135mL/min	42
LSP10-1C	14.068mL/min	43
LSP01-1BH	124.361mL/min	44
Micro Gear Pump		45
Hemodialysis Pump		47
dPOFLEX® High Precision Filling System		48
Dispensing & Filling System - Peristaltic Pump		49
Industrial Syringe Pump		50-51
Industrial Multi-Channel Syringe Pump		52
OEM Peristaltic Pump Head		53
OEM Peristaltic Pump Without Control Board		54-55
T-S403/T-S400		54
T-S500&WX10-14-H/T-S501&JY15-12-C		55
OEM Variable Speed Peristaltic Pump		56-65
OEM Fixed Speed Peristaltic Pump		66-72
Peristaltic Pump Tubing		73
LongerPump®Silicone Tubing		74
Flow Reference Curve		75-79
Peristaltic Pump Accessories		80

Biosicon® Silicone Tubing



◎ Main Features

BioSicon Silicone Tubing is based on Longer's years of research and application experience in fluid transfer and process technology with the peristaltic pump. The tubing is made of refined silicone polymer. It has high transparency, good wear resistance, low permeability, strong restitutive resilience, and is not easy to deform after compression. These features make it the optimal tubing for peristaltic pumping applications.

- >USP<88> Class VI
- >USP<87> Requirement
- >USP<85> Endotoxins <0.25EU/mL
- >FDA regulations 21CFR 177.2600
- >NSF 51
- >ROHS
- >REACH



◎ Typical Applications

- Media addition
- Ultrafiltration and concentration
- IVD reagent dispensing and filling
- Media filling
- Coolant transfer

- Fermentation control
- Oral liquids filling
- Vaccine filling
- Buffer transfer
- Saline transfer



Double-bagged, following GMP guidelines

Lot-traceable and accompanied by documentation to make the validation easy

◎ Tubing Specification

Product Code	Tubing Size	ID (mm)	OD (mm)	Wall Thickness (mm)	Length (m/pkg)	Hardness (Shore A)	Tensile Strength (MPa)	Elongation at Break (%)	Tear Strength (kN/m)	Material
05.50.786	13#	0.8	4.2	1.7	15	56-60	≥7.0	≥300	≥30	Platinum-cured silicone
05.50.766	14#	1.6	5	1.7	15	50-55	≥7.0	≥500	≥30	
05.50.767	19#	2.4	5.8	1.7	15	50-55	≥7.0	≥500	≥30	
05.50.768	16#	3.2	6.4	1.6	15	50-55	≥7.0	≥500	≥30	
05.50.769	25#	4.8	8	1.6	15	50-55	≥7.0	≥500	≥30	
05.50.770	17#	6.4	9.6	1.6	15	50-55	≥7.0	≥500	≥30	
05.50.771	18#	7.9	11.1	1.6	15	50-55	≥7.0	≥500	≥30	
05.50.772	15#	4.8	9.6	2.4	15	50-55	≥7.0	≥500	≥30	
05.50.773	24#	6.4	11.2	2.4	15	50-55	≥7.0	≥500	≥30	
05.50.774	35#	7.9	12.7	2.4	15	56-60	≥7.0	≥300	≥30	
05.50.775	36#	9.5	14.3	2.4	15	56-60	≥7.0	≥300	≥30	
05.50.776	73#	9.5	16.1	3.3	15	50-55	≥7.0	≥500	≥30	
05.50.777	82#	12.7	19.3	3.3	15	50-55	≥7.0	≥500	≥30	
05.50.778	86#	9.5	22.3	6.4	15	50-55	≥7.0	≥500	≥30	
05.50.779	88#	12.7	22.3	4.8	15	56-60	≥7.0	≥300	≥30	
05.50.780	90#	19	31.8	6.4	15	50-55	≥7.0	≥500	≥30	
05.50.781	92#	25.4	35	4.8	15	50-55	≥7.0	≥500	≥30	
05.50.760	26#	6.4	13	3.3	15	50-55	≥7.0	≥500	≥30	
05.50.761	184#	15.9	22.5	3.3	15	50-55	≥7.0	≥500	≥30	
05.50.762	185#	8	16	4	15	50-55	≥7.0	≥500	≥30	
05.50.763	186#	12	20	4	15	50-55	≥7.0	≥500	≥30	
05.50.764	187#	16	24	4	15	50-55	≥7.0	≥500	≥30	
05.50.765	188#	17	25	4	15	50-55	≥7.0	≥500	≥30	

*Temperature range: -30°C to 250°C. Can be sterilized repeatedly by high temperature and ultraviolet.

YZ Pump Head

YZ1515x, YZ2515x

Max. Flow Rate



Classic design, simple operation, wide flow range.

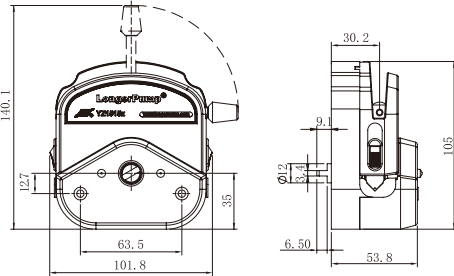

PPS housing
(Excellent chemical resistance)



PUMP HEADS

YZII15, YZII25

Max. Flow Rate

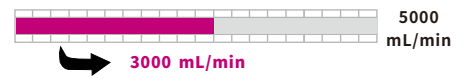

Patented Design

Patent Number: 200620026529.1

Based on the classic design of YZ1515x/YZ2515x, YZII15/YZII25 have a special tubing retention linkage which makes tubing loading easy and rapid. YZII25 accepts more tubing sizes than YZ2515x and provides a wider flow range.

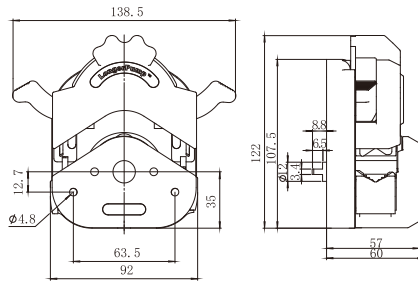

Tubing Loading Comparison



Tubing clamber needs to be lifted manually
YZ1515x/YZ2515x



Tubing clamber can be automatically opened
YZII15/YZII25

Model	Product Code	Roller Number	Roller Material	Housing Material	Speed (rpm)	Tubing	Max. Flow Rate (mL/min)	Weight (kg)
YZ1515x-A	05.01.52A	3	Stainless steel	PESU	≤600	13 [#] 14 [#] 19 [#] 16 [#]	2200	0.4
YZ1515x-B	05.01.52B	6		25 [#] 17 [#] 18 [#]		1450		
YZ1515x-C	05.01.52C	3		15 [#] 24 [#]		2200		
YZ1515x-D	05.01.52D	6		1450				
YZ2515x-A	05.01.53A	3	PESU	≤600	15 [#] 24 [#]	1600		
YZ2515x-C	05.01.53C		PPS					
YZII15	05.01.55A	3	Stainless steel	PESU	≤600	13 [#] 14 [#] 19 [#] 16 [#]	2200	0.35
YZII25	05.01.56A					15 [#] 24 [#] 35 [#] 36 [#]		

YZ Industrial Pump Head

Max. Flow Rate

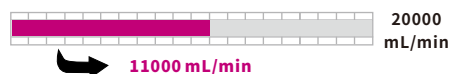

YZ35-13



Mainly for industrial applications

Two tubing retention modes

- Continuous tubing
- Tubing with fittings

Occlusion Adjustment

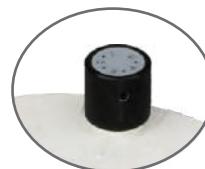

① Standard position



② Decrease occlusion



③ Increase occlusion



Tubing Fitting Assembly

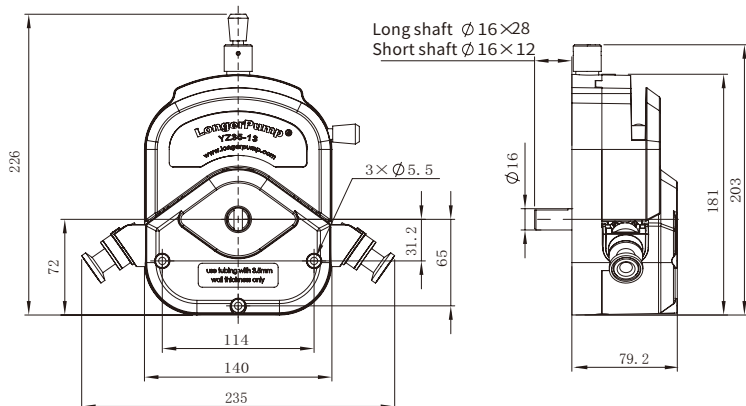

For continuous tubing



For tubing with fittings

Model	Shaft	Product Code	Roller Number	Roller Material	Housing Material	Tubing	Speed (rpm)	Max. Flow Rate (mL/min)	Weight (kg)
YZ35-13-A	Long	05.01.58A	3	Stainless Steel	PSU	73#, 82#	≤ 600 rpm	11000	1.65
YZ35-13-B	Short	05.01.58B				73#, 82#	≤ 600 rpm	11000	
YZ35-13-C	Long	05.01.75C				73#, 82#	≤ 600 rpm	11000	
YZ35-13-D	Short	05.01.75D				82A#	≤ 300 rpm	8000	
						73#, 82#	≤ 600 rpm	11000	
YZ35-13-E	Long	05.01.75E				26#	≤ 600 rpm	4000	
YZ35-13-F	Short	05.01.75F	26#	≤ 600 rpm	4000				

Standard Pump Head

BZ Series

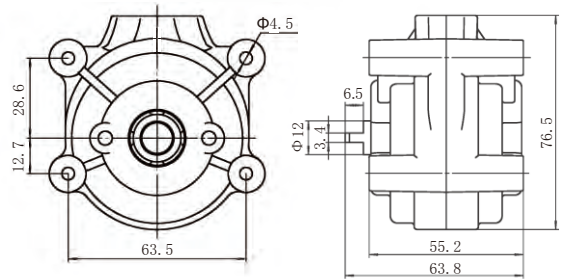
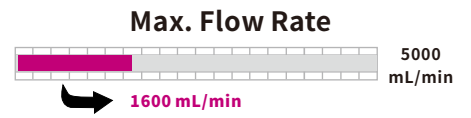

- Original design, stable flow rate, each pump head accommodates a single size of tubing.

PUMP HEADS

Flip-type Pump Head

FG15-13, FG25-13

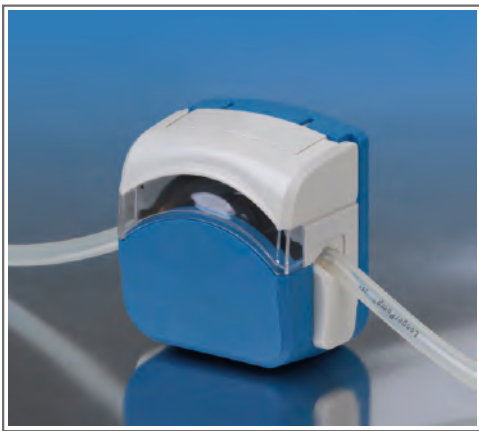
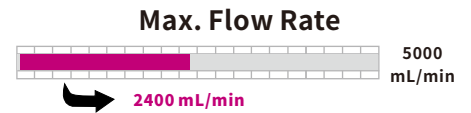

- Distinctive design, unique installation mode.

Tubing loading

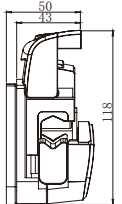
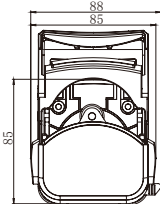
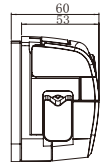
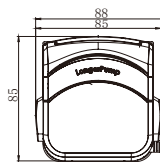
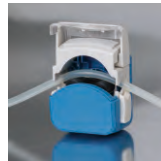

Model	Product Code	Roller Number	Roller Material	Housing Material	Speed (rpm)	Tubing	Max. Flow Rate (mL/min)	Weight (kg)
BZ15-13-A	05.01.01A	3	Stainless steel	PC	≤600	14"	150	0.31
BZ15-13-B	05.01.01B					16"	460	
BZ15-13-C	05.01.01C					25"	960	
BZ15-13-D	05.01.01D					17"	1600	
BZ25-13-B	05.01.00B					24"	1600	
FG15-13-A (Slot)	05.01.63A	3	PA6	IXEF	≤600	13" 14" 19"	2400	0.28
FG15-13-B (Tang)	05.01.63B					16" 25" 17" 18"		
FG25-13-A (Slot)	05.01.64A					15" 24"	2200	
FG25-13-B (Tang)	05.01.64B							

Multi-channel Small Flow Pump Head

DG Series

Max. Flow Rate

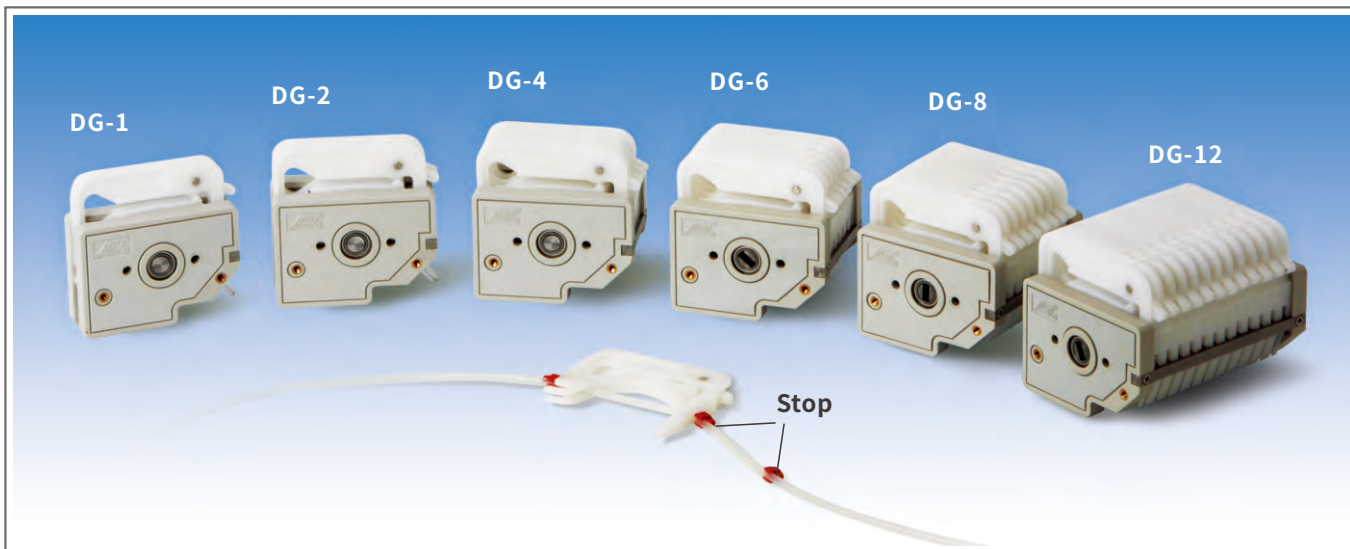

PUMP HEADS

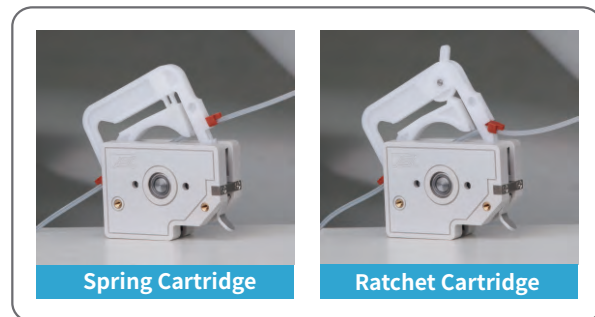
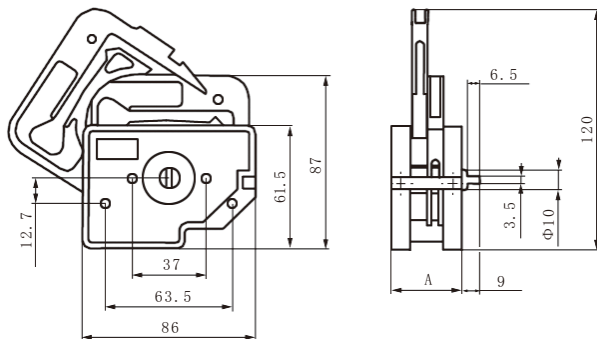

- Discrete cartridge, special tubing sets, trigger structure of DG-1&DG-2.
- Spring cartridge can adjust the occlusion automatically to accept several different tubing wall thicknesses.
- Ratchet cartridge can adjust the occlusion by adjusting ratchet position to accept several different tubing wall thicknesses.

Model	Roller Number	Product Code	Cartridge Type	Roller Material	Cartridge Material	Channel Number	Speed (rpm)	Tubing	Max. Flow Rate (mL/min)	Weight (kg)
DG-1-A	6	05.01.10A	Ratchet	Stainless Steel	DG-*-A/B cartridge material is POM 04.01.10A.40000	1	≤100	ID ≤ 3.17mm Wall Thickness 0.8mm-1.0mm	48(Single Channel)	0.20
DG-1-B	10	05.01.10B							32(Single Channel)	0.21
DG-2-A	6	05.01.11A				2			48(Single Channel)	0.26
DG-2-B	10	05.01.11B							32(Single Channel)	0.27
DG-4-A	6	05.01.12A				4			48(Single Channel)	0.39
DG-4-B	10	05.01.12B							32(Single Channel)	0.40
DG-6-A	6	05.01.13A				6			48(Single Channel)	0.51
DG-6-B	10	05.01.13B							32(Single Channel)	0.54
DG-8-A	6	05.01.14A				8			48(Single Channel)	0.63
DG-8-B	10	05.01.14B							32(Single Channel)	0.67
DG-12-A	6	05.01.15A				12			48(Single Channel)	0.88
DG-12-B	10	05.01.15B							32(Single Channel)	0.95

*PVDF cartridge is available

Multi-channel Medium Flow Pump Head

DG15 Series

PUMP HEADS

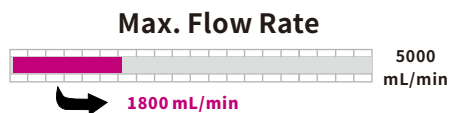

Pump Head type



DG15-24

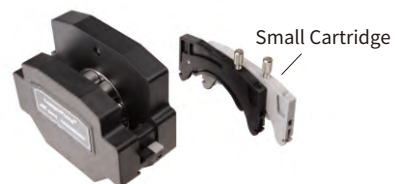

DG15-28

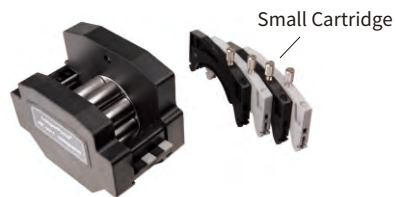

DG15-48

- DG15 - 24: 2 Channels 4 Rollers
- DG15 - 28: 2 Channels 8 Rollers
- DG15 - 48: 4 Channels 8 Rollers

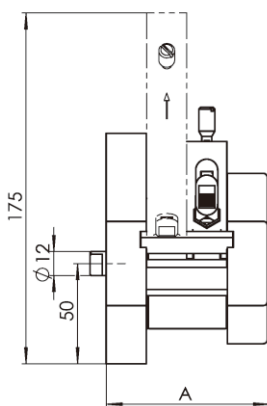
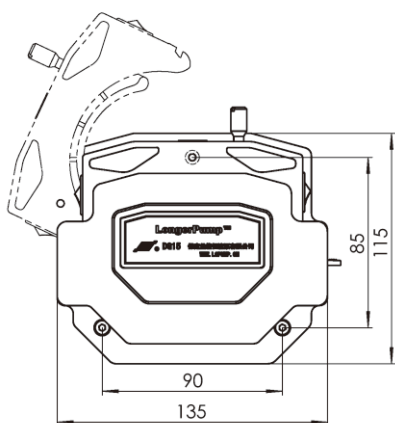

- Patented design (Patent Number: 200520026479.2), DG15-24 can replace two stacked YZ1515X.
- DG15-28 and DG15-48 can provide bigger flow rates than DG-2 and DG-4.
- Adjustable occlusion can accept several different tubing wall thicknesses.

Model	Product Code	Channel Number	Roller Number	Roller Material	Cartridge Material	Speed (rpm)	Tubing	Max. Flow Rate (mL/min)	Weight (kg)
DG15-24	05.01.16A	2	4	Stainless steel	POM	≤600	16" 25" 17"	1800 (Single Channel)	0.82
DG15-28	05.01.17A	2	8			≤100	13" 14" ID ≤ 3.17mm Wall thickness 1.0mm	75 (Single Channel)	0.67
DG15-48	05.01.18A	4	8			75 (Single Channel)	0.87		

Quick-load Pump Head

Max. Flow Rate

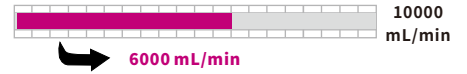

KZ25



For continuous tubing



For tubing with fittings

PUMP HEADS

Large flow rate up to 6000 mL/min, easy to load tubing with separated structure.

Two tubing retention modes

- Continuous tubing
- Tubing with fittings

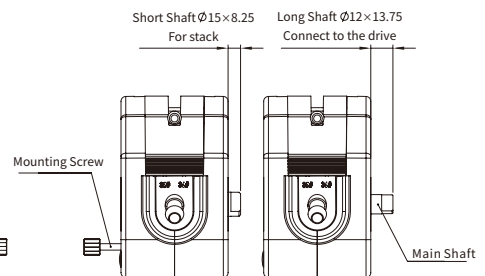
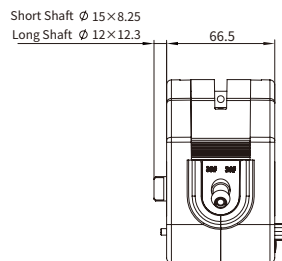
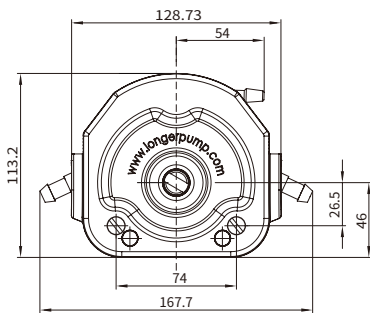
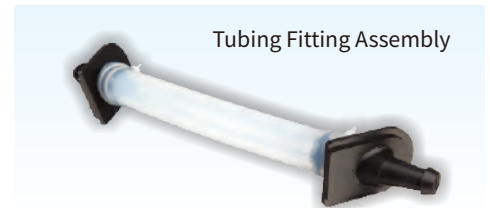

Model	Shaft	Product Code	Roller Number	Roller Material	Compression Block Material	Speed (rpm)	Tubing	Max. Flow Rate (mL/min)	Weight (kg)
KZ25-13-A	Long	05.01.25A	3	Stainless Steel	PPS	≤ 600	15" 24" 35" 36"	6000	0.79
KZ25-13-B	Short	05.01.25B							

Quick-load Industrial Pump Head

Max. Flow Rate

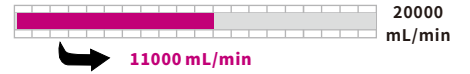

KZ35

PUMP HEADS



- Similar flow rate to YZ35-13
304 stainless steel
Mainly for industrial applications
Two tubing retention modes
- Continuous tubing
 - Tubing with fittings

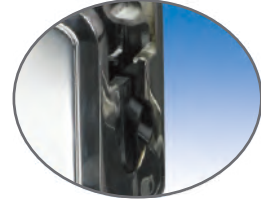

For continuous tubing



For tubing with fittings

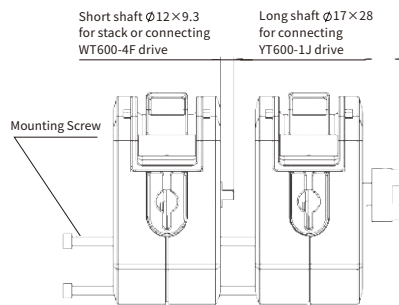
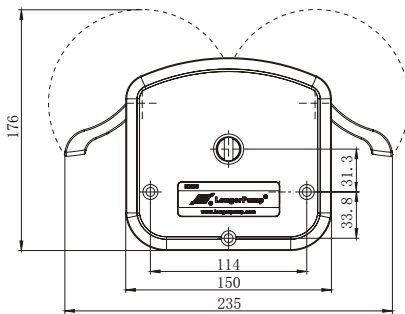

Tubing Clamper Assembly:
Tubing length between two clampers is 18cm



Tubing Fitting Assembly:
Tubing length between two fittings is 16.5cm

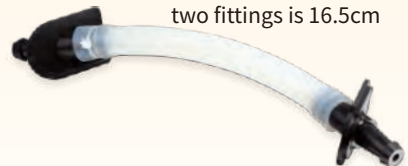

Tubing Fitting with clamp:
Tubing length between two fittings is 16.5cm

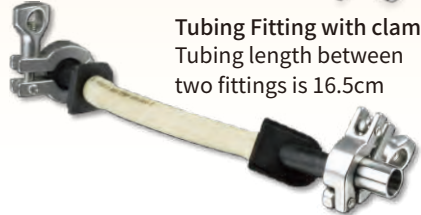

Model	Shaft	Product Code	Roller Number	Roller Material	Housing Material	Tubing	Speed (rpm)	Max. Flow Rate (mL/min)	Weight (kg)
KZ35-13-A	Long	05.01.26A	3	Stainless steel	Stainless steel	26#, 73#, 82#	≤600rpm	11000	3.7
KZ35-13-B	Short	05.01.26B				26#, 73#, 82#	≤600rpm	11000	
KZ35-13-C	Long	05.01.74C				26#, 73#, 82#	≤600rpm	11000	
						82A#, 184#	≤300rpm	9000	
KZ35-13-D	Short	05.01.74D				26#, 73#, 82#	≤600rpm	11000	
			82A#, 184#	≤300rpm	9000				

dPOFLEX® Industrial Pump Head

Max. Flow Rate

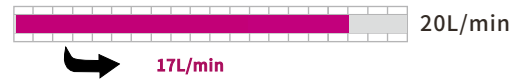

GPH, LPH



- LPH has low pulsation design for high flow rate accuracy
- GPH has two tubing retention modes: continuous tubing and tubing with fittings
- GPH could be equipped with tubing leak sensor
- Both GPH and LPH are designed with open head sensor for enhanced operator safety

PUMP HEADS

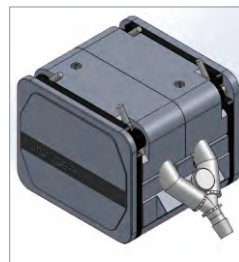
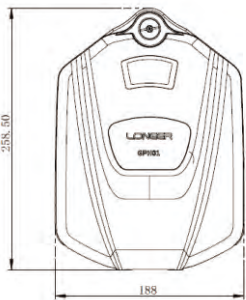

LPH with double tubing assembly for low pulsation pumping



LPH with continuous tubing for double channel pumping

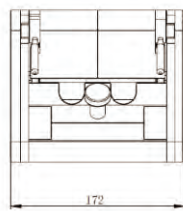
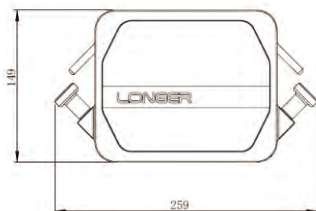

Double tubing assembly for LPH



Tubing fitting assembly for GPH

Model	Product Code	Roller Number	Roller Material	Housing Material	Speed (rpm)	Tubing ID x Wall Thickness (mm)	Reference Max. Flow Rate (L/min)	Weight (Kg)
GPH01	05.01.70A	2	304sst	Die-cast aluminum	≤265rpm	26# (6.4x3.3)	3.0	4.1
						73# (9.5x3.3)	6.0	
						82# (12.7x3.3)	10.5	
						184# (15.9x3.3)	15.0	
GPH02	05.01.71A	2	304sst	Die-cast aluminum		186# (12x4)	9.5	4.0
						188# (17x4)	17.0	
GPH03	05.01.71B	4	304sst	Die-cast aluminum		186# (12x4)	8.5	4.7
						188# (17x4)	14.0	
LPH01	05.01.72A	6	304sst	Anodized aluminum	185# (8x4)	4.5 (double tube assembly)	8.6	
					186# (12x4)	9 (double tube assembly)		
					187# (16x4)	13.5 (double tube assembly)		

dPOFLEX® High Precision Filling Pump Head

PFH01, PFH02



- Small footprint, compact structure
- Anodised aluminum housing for good corrosion protection
- Precise filling of micro-volumes as low as 30uL with accuracy better than $\pm 1\%$
- Phase compensation structure for low pulse fluid transferring

Microliter Pump Head PFH01 Capacity

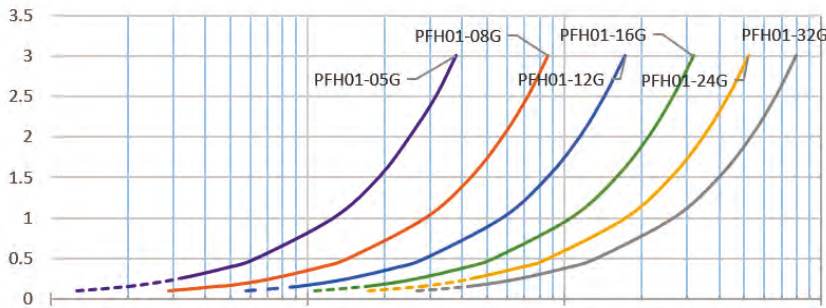

Milliliter Pump Head PFH02 Capacity

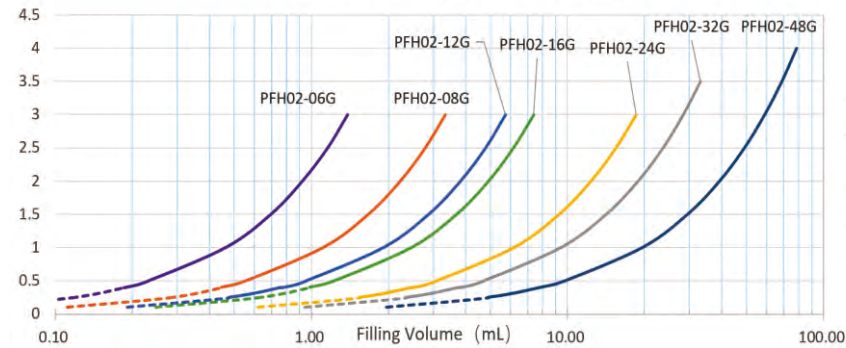

PFH01(0.51kg)

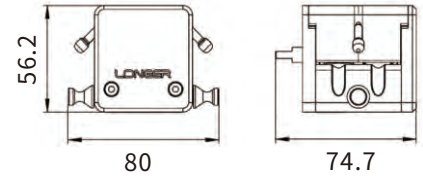

PFH02(1.26kg)

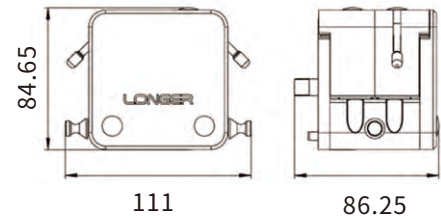

Pump Head Model	Roller Material	Roller Number	Speed (rpm)	Tubing ID (mm)	Max Flow Rate (mL/min)	Recommended Filling Volume (Accuracy $\leq \pm 1\%$)	Max Filling Volume per Second	Recommended Filling Nozzle ID (mm)
PFH01	Stainless Steel	12	≤ 350	0.5	7	30uL	118uL	0.3 or 0.6
				0.8	17	42uL	269uL	0.6
				1.2	34	90uL	534uL	1
				1.6	63	132uL	987uL	1 or 0.6
				2.4	104	400uL	1.61mL	1.6
				3.2	159	760uL	2.47mL	1.6 or 3.2
PFH02	Stainless Steel	8	≤ 450	0.6	27	0.2mL	0.42mL	0.6
				0.8	66	0.4mL	1.03mL	0.6
				1.2	114	0.5mL	1.78mL	1
				1.6	147	0.8mL	2.29mL	1 or 1.6
				2.4	371	1.16mL	5.77mL	1.6
				3.2	566	2.15mL	8.80mL	1.6 or 3.2
				4.8	1178	3mL	18.28mL	3.2 or 4.5

dPOFLEX® Peristaltic Pump Head

BPH01



- Small size, compact structure
- Spring-loaded operation for longer tubing life and good pressure control
- Four-roller design for low pulsation
- Accept various tubing sizes (with 1.6mm wall thickness) for a wide flow rate range
- Easier system configuration with AC, DC, stepper, BLDC motors

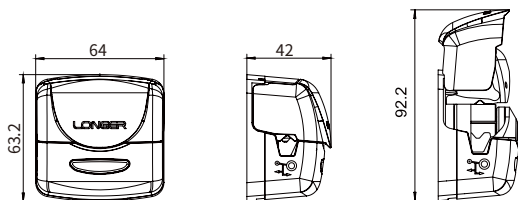

Can be integrated with AC, DC, stepper, BLDC motor for various control mode and easier system configuration

Flip-type for easier tubing loading

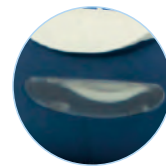

Running status can be easily monitored through the transparent PC window

Product Model	Product Code	Roller Number	Roller Material	Housing Material	Speed (rpm)	Tubing	Flow Rate Reference (mL/min)		Weight (kg)
							@400rpm	@600rpm	
dPOFLEX® BPH01	05.01.73A	4	PA6+MOS2	IXEF	Continuous flow ≤400rpm Intermittent flow ≤600rpm	13#	14	21	0.1
						14#	57	85	
						19#	117	175	
						16#	190	285	
						25#	353	530	

Small Flow, Low Pulse, Dispensing Pump Head

Max. Flow Rate



DMD15-13

Phase compensation structure



- Special tubing assembly, low pulse, high accuracy.
- Designed for high precision and small volume dispensing.
- Compact size, easy to use.

PUMP HEADS

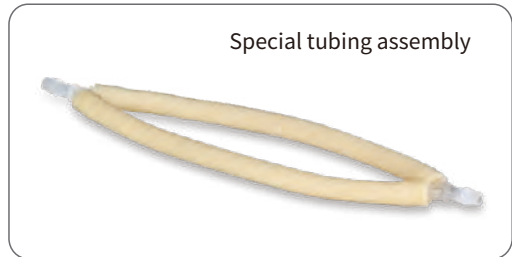
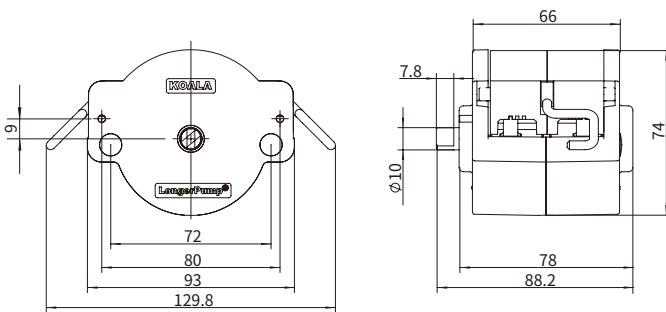

Phase compensation schematic diagram

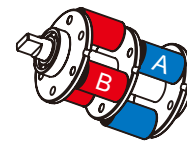
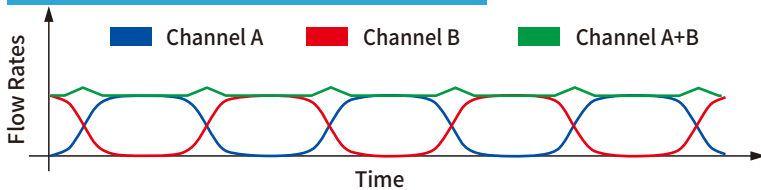

Phase compensation structure diagram

Model (Product Code, Housing Material)	Roller Material	Roller Number	Speed (rpm)	Tubing	Max. Flow Rate (mL/min)	Ref. Dispensing Volume (mL)	Ref. Dispensing Time(s)	Precision	Dispensing Head ID (mm)	Weight (kg)
DMD15-13-B(05.01.04B, PESU) DMD15-13-D(05.01.04D, PPS)	Stainless Steel	3	≤600	2×13"	80	>0.8	>0.6	±2%	≤0.5	0.43
						>1.6	>1.2	±1%	≤0.5	
				2×14"	300	>3	>0.6	±2%	≤1.0	
						>6	>1.2	±1%	≤1.0	
				2×19"	620	>6.2	>0.6	±2%	≤1.5	
						>12.4	>1.2	±1%	≤1.5	
				2×16"	960	>9.6	>0.6	±2%	≤2.0	
						>19.2	>1.2	±1%	≤2.0	
2×25"	2070	>20.7	>0.6	±2%	≤3.0					
		>41.4	>1.2	±1%	≤3.0					

Peristaltic Pump ■ Series

Intelligent Peristaltic Pump

L100-1F, L100-1FS, L300-1F, L300-1FS, L600-1F, L600-1FS

Max. Flow Rate

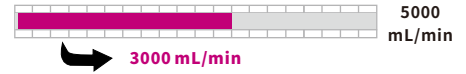

PERISTALTIC PUMP



7 inch color display, full touch screen and intuitive graphic interface, provide easy-to-use operations

Customize parameters by programming, and the parameter methods can be stored and easily recalled

Multiple function modules and intelligent algorithms are designed for a wide variety of applications, including routine and multi-step complex applications

• L100-1F, L300-1F, L600-1F

Pump can be controlled through touch screen, foot switch, analog signal and communication commands, combined with a variety of interfaces (USB, RJ11, DB9 etc.) for easy system connection

• L100-1FS, L300-1FS, L600-1FS

Automatic identification of pump head and tubing, simplify the operation process and provide reliable guarantee for high-precision fluid transferring

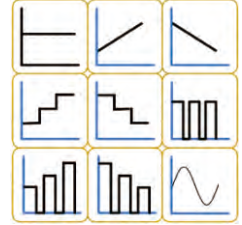

Running Control Module



Parameter Program Configuration

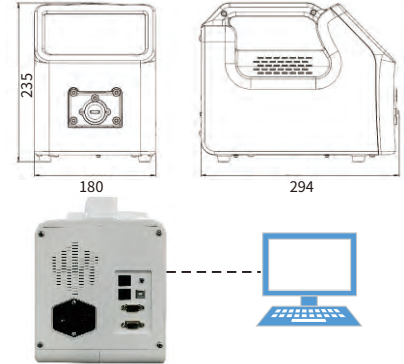

Upgrade the pump software through PC

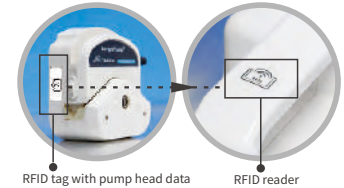

Automatic identification of pump head and tubing

	L100-1F / L100-1FS	L300-1F / L300-1FS	L600-1F / L600-1FS
Speed	≤100rpm, CW/CCW	≤300rpm, CW/CCW	≤600rpm, CW/CCW
Speed resolution	0.1rpm	0.1rpm resolution when speed <100rpm, 1rpm resolution when speed ≥100rpm	
Flow rate	0.15uL/min-500ml/min	0.15uL/min-1500mL/min	0.15uL/min-3000mL/min
Dispensing volume	0.1mL-9999L (accuracy of ±2% with calibration)		
Calibration	Improve the flow rate and dispensing volume accuracy.		
Display	7Inch 1024×600 color LCD		
Language	Chinese or English, set as needed		
Control mode	Touch screen control, footswitch control, external signal control and communication control		
Work mode	Programming		
Programming function	Running control module: constant, ramp up/down, stepped up/down, sine, constant dispensing, incremental/decremental dispensing. Logic control module: direction, delay, event trigger, status output, pause, jump, loop, stop. Configure multi-step program with multiple modules for complex application		
External control	Start/stop control, direction control: logic level signal or switch signal (dry contact) Speed control: 0-5V, 0-10V, 4-20mA or 0-10kHz with uniform interface, max speed can be set.		
Communication control	USB or RS485(RJ11) interface, Modbus protocol, multiple baud rate (1200/ 2400/ 4800/ 9600/ 19200/ 38400bps)		
Status output	Output logic level signals to indicate pump running status, direction status, and other custom status.		
Parameter method function	7 parameter methods can be stored and easily recalled, 1 external control method is preset		
Scheduled start	The delay start time can be set, and the pump will start running at desired time.		
Back suction	Antidrip through setting back suction angle and delay time for high dispensing accuracy		
Dispensing volume setting range	0.001uL-9999L		
Dispensing time and Interval time	0.5s-9000s		
Dispensing cycle	1-999999(0 for unlimited)		
Time in fluid transferring modules	1s-9000s (0s for continuous transfer without time limit)		
Delay time setting range	0.5s-9000s		
Prime	Fast filling and emptying at full speed		
EMC	Comply with EN 61326-1:2013		
Dimension (L×W×H)	294×180×235(mm)		
Power Supply	L100-1F-A/L300-1F-A: AC220V±20%, 50Hz/60Hz L100-1F-B/L300-1F-B: AC110V±20%, 50Hz/60Hz		AC100V-240V, 50Hz/60Hz
Power Consumption	35W	55W	100W
Condition	temperature: 0°C-40°C relative humidity: <80%		
IP rating	IP31		
Weight	5.0kg		

Pump Head	Tubing	Max Flow Rate Reference (mL/min)			Weight(kg)
		L100-1F/L100-1FS	L300-1F/L300-1FS	L600-1F/L600-1FS	
YZ1515x, YZ1115	13", 14", 19", 16", 25", 17", 18"	380	1100	2200	5.4
YZ2515x	15", 24"	266	800	1600	5.4
YZ1125	15", 24", 35", 36"	500	1500	3000	5.4
FG15-13	13", 14", 19", 16", 25", 17", 18"	430	1200	2400	5.3
FG25-13	15", 24"	270	1100	2200	5.3
DMD15-13-B	2×13", 2×14", 2×19", 2×16", 2×25"	375	1035	2070	5.4
BZ15-13-A	14"	22	75	150	5.3
BZ15-13-B	16"	80	230	460	5.3
BZ15-13-C	25"	150	480	960	5.3
BZ15-13-D	17"	270	800	1600	5.3
BZ25-13-B	24"	250	800	1600	5.3
DG15-24	16", 25", 17"	300(Single Channel)	900(Single Channel)	1800(Single Channel)	5.8
DG15-28	13", 14", ID≤3.17mm, Wall thickness: 1mm	75(Single Channel, speed≤100rpm)			5.7
DG-(1,2,4,6,8)6rollers	ID≤3.17mm, Wall thickness: 0.8-1mm	48(Single Channel, speed≤100rpm)			5.2-5.6
DG-(1,2,4)10rollers	ID≤3.17mm, Wall thickness: 0.8-1mm	32(Single Channel, speed≤100rpm)			5.2-5.4

Mini Series Peristaltic Pump

Max. Flow Rate



GM100-2A&WX10



- Compact size and structure
- Speed control 10,000:1
- Continuous and timer modes for different applications
- Keypad and footswitch control for local operation
- Low-noise design
- Including the 4-roller pump head WX10-14 with low pulsation

Typical Applications

- Cell culture
- Microbial fermentation
- Filtration and chromatography
- Reagent titration
- Sterile medicine transfer
- Water treatment reagent dosing
- Food additive transfer
- Microfluidic control

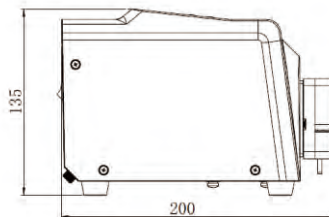
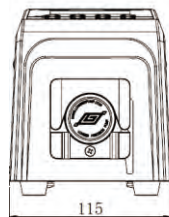

Use slip-on stops to secure the tubing in place.

PERISTALTIC PUMP

	GM100-2A&WX10
Pump speed	0-100rpm
Speed resolution	0.01 rpm (speed<10rpm); 0.1rpm (10rpm≤speed≤100rpm)
Display	LCD screen for pump speed, running direction, time, start/stop status and work mode
Running direction	Clockwise or counter-clockwise, can be toggled during running
Work mode	Continuous or timer mode
Control mode	Keypad or footswitch control
Keypad control	Set the parameters and control the pump via keypad: start/stop, running direction, prime function, speed adjustment, work mode, timer
Footswitch control	Control the start/stop via a footswitch
Timer function	In timer mode, the pump runs and stops based on the set timer duration. Timer range: 0.1s to 999h.
Runtime counter	In continuous mode, the pump automatically records the runtime and can accumulate the multiple operation periods (reset upon power-up). Timing range: 0.1s-999h
Keypad lock	To prevent misoperation
Pump status when powered up	Stop
Parameter retention	Run and system parameters are saved after power loss
Prime	Fast filling or emptying at full speed
Dimensions (L*W*H)	200mmx115mmx135mm (including pump head)
Power supply for adapter	AC100-240V, 50Hz-60Hz
Power supply for pump	DC24V/8W
Working condition	Environment temperature:0°C-40°C, relative humidity:<80%
IP rating	IP31
Weight	1.25kg (including pump head)

Pump Model	Product Code	Pump Head Model (included)	Roller Number	Pump Head Material	Tubing	Max Flow Rate Reference (mL/min)
GM100-2A&WX10	05.02.07A	WX10-14-A	4	Housing:ABS Roller:POM	ID≤3.17mm, W.T.: 0.8-1mm	40

Mini Series Peristaltic Pump

GM200-1A/GM200-2A/GM400-1A/GM400-2A

Max. Flow Rate

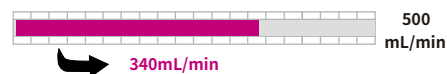

- Compact size and structure
- Speed control 20,000:1 or 40,000:1
- Continuous and timer modes for different applications
- Keypad and footswitch control for local operation
- Variety of remote control options for easy system integration
- Low-noise design
- Mounted with 4-roller pump head BPH01 for low pulsation

Typical Applications

- Cell culture
- Microbial fermentation
- Filtration and chromatography
- Reagent titration
- Sterile medicine transfer
- Water treatment reagent dosing
- Water treatment sample transfer
- Food additive transfer

PERISTALTIC PUMP

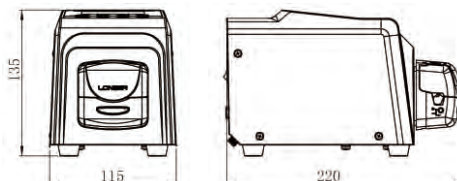
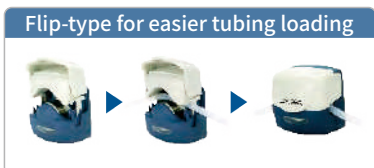

	GM200-1A	GM400-1A	GM200-2A	GM400-2A
Pump speed	0-200rpm	0-400rpm	0-200rpm	0-400rpm
Speed resolution	0.01 rpm (speed<10rpm); 0.1rpm (10rpm≤speed<100rpm); 1rpm (100rpm≤speed≤max)			
Display	LCD screen for pump speed, running direction, time, start/stop status, work mode and control mode			
Running direction	Clockwise or counter-clockwise, can be toggled during running			
Work mode	Continuous or timer mode			
Control mode	Keypad, footswitch, external signal or communication control		Keypad or footswitch control	
Keypad control	Set the parameters and control the pump via keypad: start/stop, running direction, prime status, speed adjustment, work mode, control mode, timer, communication control parameters		Set the parameters and control the pump via keypad: start/stop, running direction, prime status, speed adjustment, work mode, timer	
External control	Start/stop: switch signal, level trigger or pulse trigger Running direction control: switch signal, level trigger or pulse trigger Speed control: 4-20mA/0-5V/0-10V/0-10kHz, The valid speed range can be configured through communication commands		N/A	
Communication control	RS485 interface, Modbus RTU protocol and Longer OEM protocol		N/A	
Footswitch control	Control the start/stop via a footswitch			
Timer function	In timer mode, the pump runs and stops based on the set timer duration. Timer range: 0.1s to 999h.			
Runtime counter	In continuous mode, the pump automatically records the runtime and can accumulate the multiple operation periods (reset upon power-up). Timing range: 0.1s-999h			
Keypad lock	To prevent misoperation			
Pump status when powered up	Timer mode: stop Continuous mode: stop as default, can be set to the status before power-off via communication command		Stop	
Parameter retention	Run and system parameters are saved after power loss in both keypad control and communication control modes.			
Prime	Fast filling or emptying at full speed			
Dimensions (L*W*H)	220mm x 115mm x 135mm (including pump head)			
Power supply for adapter	AC100-240V, 50Hz-60Hz,			
Power supply for pump	DC24V/8W	DC24V/16W	DC24V/8W	DC24V/16W
Working condition	Environment temperature:0°C-40°C, relative humidity:<80%			
IP rating	IP31			
Weight	1.35kg (including pump head)			

Pump Drive Model	Pump Head Model	Speed	Roller Number	Pump Head Material	Tubing	Max Flow Rate Reference (mL/min)
GM200-1A (Product Code: 05.02.03A)	BPH01 (Product Code: 05.01.73A)	≤200rpm	4	Housing: PA6+MOS2 Roller: IXEF	13#, 14#, 19#,	170
GM200-2A (Product Code: 05.02.03B)						
GM400-1A (Product Code: 05.02.03C)		≤400rpm			16#, 25#	340
GM400-2A (Product Code: 05.02.03D)						

Mini Series Peristaltic Pump

GM200-2B/GM400-2B

Max. Flow Rate



- Compact size and structure
- Speed control 20,000:1 or 40,000:1
- Continuous and timer modes for different applications
- Keypad and footswitch control for local operation
- Low-noise design
- Compatible with various peristaltic pump heads with a wide flow range

Typical Applications

Cell culture
Microbial fermentation
Filtration and chromatography
Reagent titration

Sterile medicine transfer
Water treatment reagent dosing
Water treatment sample transfer
Food additive transfer

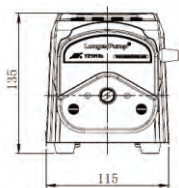

GM200/GM400+YZ15/YZ25

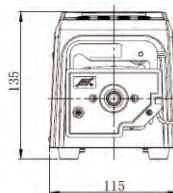
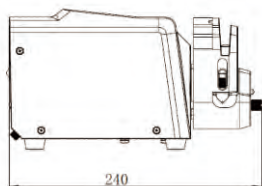

GM200/GM400+DG-1

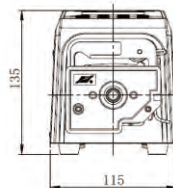
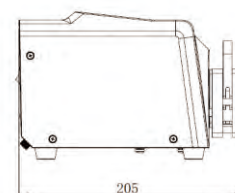

GM200/GM400+DG-2

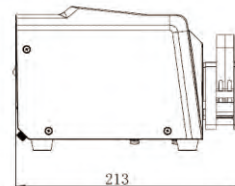

	GM200-2B	GM400-2B
Pump speed	0-200rpm	0-400rpm
Speed resolution	0.01 rpm (speed<10rpm);0.1rpm (10rpm≤speed<100rpm);1rpm (100rpm≤speed≤max)	
Display	LCD screen for pump speed, running direction, time, start/stop status and work mode	
Running direction	Clockwise or counter-clockwise, can be toggled during running	
Work mode	Continuous or timer mode	
Control mode	Keypad or footswitch control	
Keypad control	Set the parameters and control the pump via keypad: start/stop, running direction, prime function, speed adjustment, work mode, timer	
Footswitch control	Control the start/stop via a footswitch	
Timer function	In timer mode, the pump runs and stops based on the set timer duration. Timer range: 0.1s to 999h.	
Runtime counter	In continuous mode, the pump automatically records the runtime and can accumulate the multiple operation periods (reset upon power-up). Timing range: 0.1s-999h	
Keypad lock	To prevent misoperation	
Pump status when powered up	Stop	
Parameter retention	Run and system parameters are saved after power loss	
Prime	Fast filling or emptying at full speed	
Dimensions (L*W*H)	175mmx115mmx135mm (pump drive only)	
Power supply for adapter	AC100-240V, 50Hz-60Hz	
Power supply for pump	DC24V/15W	DC24V/30W
Working condition	Environment temperature:0°C-40°C, relative humidity:<80%	
IP rating	IP31	
Weight	1.7kg (pump drive only)	

Pump Drive Model	Pump Head Model	Speed	Roller Number	Channel Number	Pump Head Material	Tubing	Max Flow Rate Reference (mL/min)
GM200-2B (Product Code: 05.02.05A)	YZ1515x	≤200rpm	3	1	Housing: PESU or PPS Roller: Stainless steel	13#, 14#, 19#, 16#, 25#, 17#, 18#	760
	YZ2515x		3	1		15#, 24#	540
	DG-1 (6rollers)	≤100rpm	6	1	Cartridge: POM or PVDF Roller: Stainless steel	ID≤3.17mm, W.T.: 0.8-1mm	48(Single Channel)
	DG-1 (10rollers)		10	1			32(Single Channel)
	DG-2 (6rollers)		6	2			48(Single Channel)
DG-2 (10rollers)	10	2	32(Single Channel)				
GM400-2B (Product Code: 05.02.05B)	YZ1515x	≤400rpm	3	1	Housing: PESU or PPS Roller: Stainless steel	13#, 14#, 19#, 16#, 25#, 17#, 18#	1520
	YZ2515x		3	1		15#, 24#	1120

Basic Peristaltic Pump

BT100-3J

PERISTALTIC PUMP



Speed	0.1rpm-100rpm, CW/CCW.
Speed resolution	0.1rpm
Control mode	Membrane keypad, external signal control and communication control are available
Display	3-digit LED display for current speed, 3 LED indicators for operating status
External control	Start/stop, direction and speed control (4-20mA, 0-5V, 0-10V, 0-10kHz external control module optional)
Communication interface	RS485
Power-off memory	Return to previous status when powered on
Prime	For fast filling and emptying at full speed
Dimension (L×W×H)	232×142×149 (mm)
Power supply	AC 100V-240V 50/60Hz
Operating temperature	0 to 40°C
Relative humidity	<80%
IP rating	IP20
Weight	2.3kg

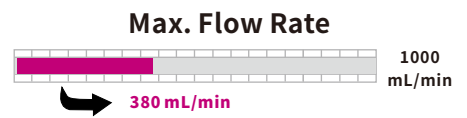

Pump Head Options



YZ1515x
YZ2515x



YZII15
YZII25



BZ15
BZ25



DMD15-13-B
DMD15-13-D



DG-1



DG-2
DG-4



DG15-24
DG15-28

• Commonly used in laboratorial applications

Model	Product Code	Pump Head	Tubing	Max. Flow Rate (mL/min)
BT100-3J	05.02.11B	YZ1515x(3 rollers), YZII15	13" 14" 19" 16" 25" 17" 18"	380
		YZ2515x, YZII25	15" 24"	270
		DMD15-13-B, DMD15-13-D	2×13", 2×14", 2×19", 2×16", 2×25"	350
		BZ15-13-A	14"	22
		BZ15-13-B	16"	80
		BZ15-13-C	25"	150
		BZ15-13-D	17"	270
		BZ25-13-B	24"	250
		DG-1, DG-2, DG-4(6 rollers)	ID≤3.17mm, Wall Thickness 0.8-1mm	48 (Single Channel)
		DG-1, DG-2, DG-4(10 rollers)		32 (Single Channel)
		DG15-24	16", 25", 17"	300 (Single Channel)
		DG15-28	ID≤3.17mm, Wall Thickness 1mm	75 (Single Channel)
13", 14"	75 (Single Channel)			

Basic Peristaltic Pump

BT300-2J/ BT600-2J

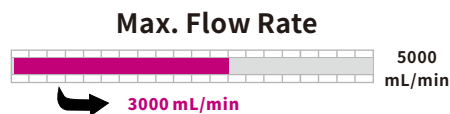

- Mainly used in laboratorial applications. Higher speed and flow rate than BT100-3J.

Pump Head Options



	BT300-2J	BT600-2J
Speed	1rpm-300rpm, CW/CCW	1rpm-600rpm, CW/CCW
Speed resolution	1rpm	
Control mode	Control panel, external signal control and communication control are available	
Display	3-digit LED display for current speed	
External control	Start/stop, direction and speed control (4-20mA, 0-5V, 0-10V, 0-10kHz External control module optional)	
Communication interface	RS485	
Power-off memory	Return to previous status when powered on	
Prime	For fast filling and emptying at full speed	
Dimension (L×W×H)	285×207×180 (mm)	
Power supply	AC 90V-260V/48W	AC 90V-260V/100W
Operating temperature	0 to 40°C	
Relative humidity	<80%	
IP rating	IP31	
Weight	3.6kg	3.8kg



Model	Product Code	Pump Head	Tubing	Max. Flow Rate (mL/min)	Weight (kg)
BT300-2J	05.02.31A	YZ1515x, YZII15	13" 14" 19" 16" 25" 17" 18"	1140	4.0
		YZ2515x	15" 24"	840	
		YZII25	15" 24" 35" 36"	1500	
		DG15-24	16" 25" 17"	900 (Single Channel)	
BT600-2J	05.02.62A	YZ1515x, YZII15	13" 14" 19" 16" 25" 17" 18"	2200	4.2
		YZ2515x	15" 24"	1600	
		YZII25	15" 24" 35" 36"	3000	
		DG15-24	16" 25" 17"	1800 (Single Channel)	

Basic Peristaltic Pump

WT600-2J

PERISTALTIC PUMP



Speed	60rpm-600rpm, CW/CCW.
Speed resolution	1rpm
Speed accuracy	≤±1%
Control mode	Control panel, external signal control and communication control are available.
Display	3-digit LED display for current speed
External control	Start/stop, direction and speed control (4-20mA, 0.5-5V, 1-10V, 1-10kHz external control module optional).
Communication interface	RS485
Power-off memory	Return to previous status when powered on
Prime	For fast filling and emptying at full speed
Dimension (L×W×H)	285×207×180 (mm)
Power supply	AC 220V±20%/200W or AC 110V±20%/200W
Operating temperature	0 to 40°C
Relative humidity	<80%
IP rating	IP31
Weight	5.2kg

Flow Rates



Pump Head Options



YZ1515x
YZ2515x



YZII15
YZII25



KZ25



DG15-24

- Mainly used in laboratorial applications. With brushless motor, can drive multi-pump heads.



Model (Product code, Power supply)	Pump Head	Tubing	Flow Rate (mL/min)	Weight (kg)
WT600-2J-A (05.02.63A, AC220V)	(1, 2, 3, 4)×YZ1515x	13" 14" 19" 16" 25" 17" 18"	4-2200 (Single Channel)	5.6-6.8
	(1, 2, 3, 4)×YZII15			
	(1, 2, 3, 4)×YZ2515x	15" 24"	100-1600 (Single Channel)	
WT600-2J-B (05.02.63B, AC110V)	(1, 2)×YZII25	15" 24" 35" 36"	100-3000 (Single Channel)	5.6-6.0
	DG15-24	16" 25" 17"	50-1800 (Single Channel)	6.0
	(1, 2)×KZ25	15" 24" 35" 36"	200-6000 (Single Channel)	6.0-6.8

Basic Peristaltic Pump

WT600-3J

Flow Rates

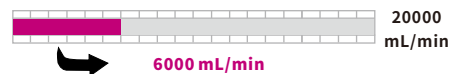

PERISTALTIC PUMP

Speed	60rpm-600rpm, CW/CCW
Speed resolution	1rpm
Speed accuracy	≤ ±1%
Control mode	Membrane keypad, external signal control and communication control are available
Display	3-digit LED display for current speed, 4 LED indicators for operating status
External control	Start/stop, direction and speed control (4-20mA, 0.5-5V, 1-10V, 1-10kHz external control module optional)
Communication interface	RS485
Power-off memory	Return to previous status when powered on
Prime	For fast filling and emptying at full speed
Dimension (L×W×H)	273×190×272 (mm)
Power supply	AC 220V±20%/200W or AC 110V±20%/200W
Operating temperature	0 to 40°C
Relative humidity	<90%
IP rating	IP55
Weight	7.3kg

- Mainly used in industrial applications.
- With brushless motor, can drive multi-pump heads.
- Stainless steel housing, high IP rating.



Model (Product code, Power supply, Speed control signal)	Pump Head	Tubing	Flow Rate (mL/min)	Weight (kg)
WT600-3J-A (05.02.64A, AC220V, 0.5-5V) WT600-3J-B (05.02.64B, AC220V, 1-10V) WT600-3J-C (05.02.64C, AC220V, 4-20mA)	(1, 2, 3, 4)×YZ1515x	13" 14" 19" 16"	4-2200 (Single Channel)	7.7-8.9
WT600-3J-D (05.02.64D, AC220V, 1kHz-10kHz) WT600-3J-E (05.02.64E, AC220V, RS485)	(1, 2, 3, 4)×YZII15	25" 17" 18"		
WT600-3J-F (05.02.64F, AC110V, 0.5-5V) WT600-3J-G (05.02.64G, AC110V, 1-10V)	(1, 2, 3, 4)×YZ2515x	15" 24"	100-1600 (Single Channel)	7.7-8.1
WT600-3J-H (05.02.64H, AC110V, 4-20mA) WT600-3J-I (05.02.64I, AC110V, 1kHz-10kHz)	(1, 2)×YZII25	15" 24" 35" 36"	100-3000 (Single Channel)	
WT600-3J-J (05.02.64J, AC110V, 1kHz-10kHz) WT600-3J-K (05.02.64K, AC110V, RS485)	DG15-24	16" 25" 17"	50-1800 (Single Channel)	8.1
	(1, 2)×KZ25	15" 24" 35" 36"	200-6000 (Single Channel)	8.1-8.9



Basic Peristaltic Pump

YT600-1J

Flow Rates



PERISTALTIC PUMP

IP54



Pump Head Options



YZ35-13



KZ35

- Mainly used in industrial applications.
- With DC motor, can drive multi-pump heads.
- Stainless steel housing, high IP rating.

Speed	60rpm-600rpm, CW/CCW
Control mode	Control panel and external signal control are available
External control	Start/stop, speed control (4-20mA, 1-10V, 1-10kHz external control mode optional)
Dimension (L×W×H)	380×326×214 (mm)
Power supply	AC 220V±20%/400W
Operating temperature	0 to 40°C
Relative humidity	<80%
IP rating	IP54
Weight	20kg

Use water-proof aviation plug & socket as external control interface and power interface.



Model (Product code, Speed control signal)	Pump Head	Tubing	Flow Rate (mL/min)	Weight (kg)
YT600-1J-A (05.02.52A, 4-20mA) YT600-1J-B (05.02.52B, 1-10V) YT600-1J-C (05.02.52C, 1-10kHz)	(1, 2) × KZ35-13 (1, 2) × YZ35-13	73" 82"	600-11000 (Single Channel)	23.7-27.4 21.6-23.2

Basic Peristaltic Pump

JL350-2J

- Mainly used in industrial applications.
- AC motor, frequency control, high IP rating.
- Combine special convex rollers with concave compression block to run stably and prolong tubing life.

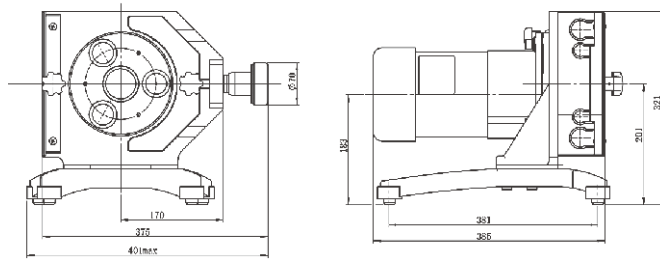

Fluid transferring in industrial applications

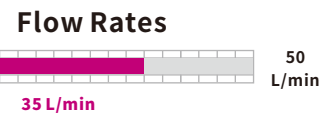
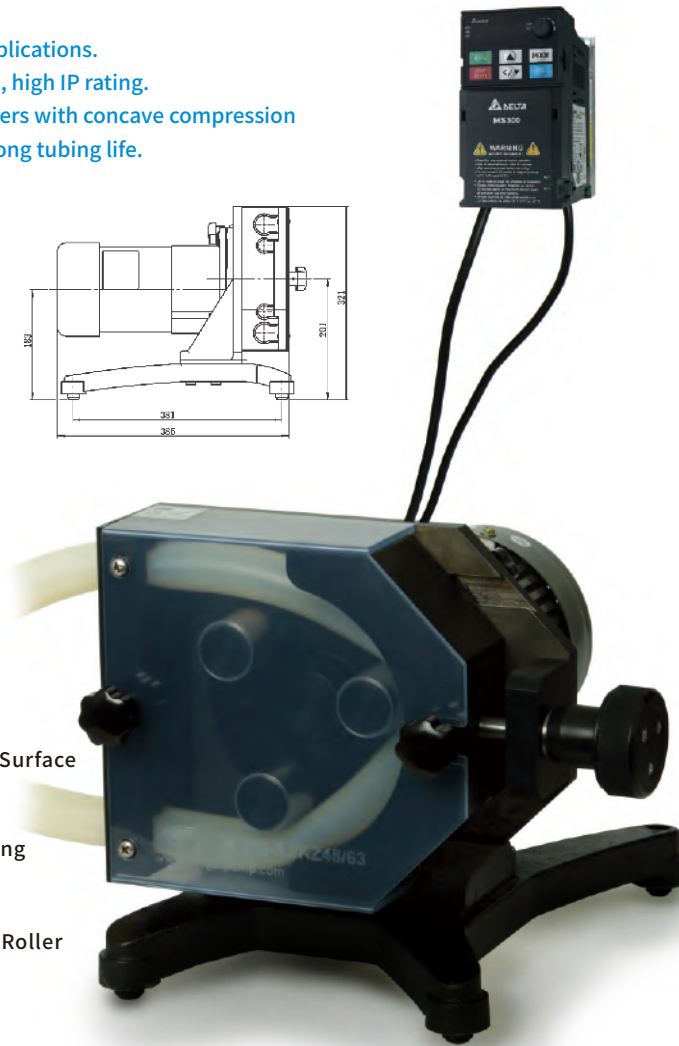
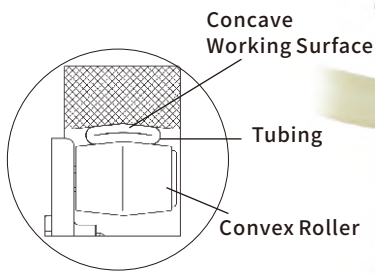

Tubing Loading

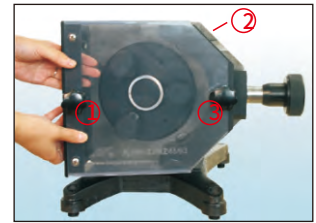

- A**
1. Turn the knob ①, ② counter clockwise.
 2. Turn the hand wheel to loosen the compression block.
 3. Pull the knob ③ and take off the front cover.

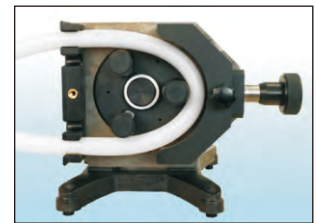

- B**
4. Select suitable tubing slots, place the tubing between the roller and the compression block, then put the tubing in the corresponding tubing slots.

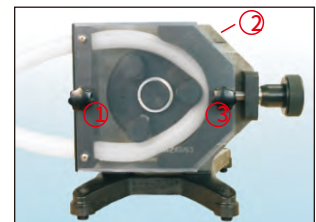

- C**
5. Pull the knob ③, insert the front cover, tighten the knob CW to fix the front cover ①.
 6. Turn the hand wheel and adjust the occlusion between the roller and the compression block.
 7. Tighten the knob ② and fix the compression block.

PERISTALTIC PUMP

Speed	30rpm-350rpm, CW/CCW
Speed resolution	0.6rpm
Control mode	keypad control or external signal control
Display	LCD for running information
Speed control	0-5V, 0-10V, 4-20mA linear control
Start/stop signal input	Switch signal control
Direction signal input	Switch signal control
Communication function	RS485 interface, Modbus RTU protocol
Memory function	Storing the running parameter automatically
Dimension (L×W×H)	417×401×321 (mm)
Power supply	AC 220V±10%/400W
Operating temperature	0 to 40°C
Relative humidity	<80%
IP rating	IP55(excluding frequency converter)
Weight	32kg



IP55

Tubing with fitting assembly

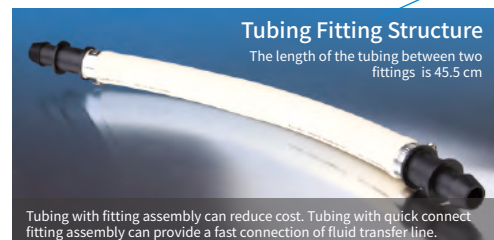

Tubing with fitting assembly can reduce cost. Tubing with quick connect fitting assembly can provide a fast connection of fluid transfer line.

Model	Product Code	Pump Head	Tubing	Flow Rate (L/min)	Weight (kg)
JL350-2J	05.02.34A	KZ48	88"	1.3-15	32
			92"	3-35	

Basic Peristaltic Pump

BQ50-1J

PERISTALTIC PUMP



Speed	1rpm-50rpm, CW/CCW
Speed resolution	1rpm (manually control), 0.1rpm (external control)
Control mode	Hand-held controller, external signal control and communication control are available
Display	Hand-held controller displays speed and running status
External control	Start/stop, direction and speed control (4-20mA, 0-5V, 0-10V, 0-10kHz external control module optional)
Communication	RS485
Power-off memory	Return to previous status when powered on
Prime	For fast filling and emptying at full speed
Dimension (L×W×H)	135mm×72mm×72mm (drive + pump head) 105mm×50mm×16mm (hand-held controller)
Power supply	DC 12V/10W (pump) AC 90V-260V/10W (adapter)
Operating temperature	0 to 40°C
Relative humidity	<80%
IP rating	IP31
Weight	0.5kg
Standard configuration	Drive with pump head, hand-held controller, adapter, data wire
Optional accessories (Order separately)	Small V-base, polished stainless steel pole, fixing plate, specific tubing

Model	Product Code	Color	Pump Head	Roller Number	Pump Head Material	Tubing	Max. Flow Rate (mL/min)	Weight (kg)
BQ50-1J-A	05.02.02A	Black	WX10-14-A	4	ABS, POM	ID ≤3.17 (mm) Wall Thickness 0.8-1 (mm)	20	0.5
BQ50-1J-B	05.02.02B		WX10-14-C		ABS, PVDF			
BQ50-1J-C	05.02.02C		WX10-18-A	8	ABS, POM			
BQ50-1J-D	05.02.02D		WX10-18-C		ABS, PVDF			

* CE certified product based on request *

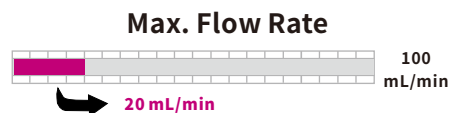

- Mainly used in laboratorial applications.
- Embedded or rack-mounted.

Installation Drawing

-
1. Insert pump into the mounting hole of user instrument.
 2. Insert the clips into the slots of the pump housing.
 3. Push the clips and fix the pump in user instrument.



Standard Peristaltic Pump

L100-1S-2

Flow Rate

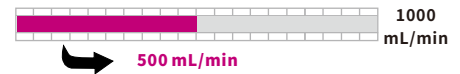

* Product L100-1S-1 (product code:050241A) has same performance and parameters as L100-1S-2, but only can be controlled by keypad.

- Mainly designed for Laboratory and light industry applications.
- With precise speed control in 0.01rpm resolution (10000:1 turndown ratio) and a flow rate calibration function, the pump has higher accuracy and a wider range of flow rates.
- With the intelligent fan control, the pump makes less noise and has better energy efficiency.
- LCD with specially designed screen displays parameters and running status, this provides the necessary information for correct operation.

PERISTALTIC PUMP

Pump Head Options



YZ1515x, YZ2515x



YZII15, YZII25



BZ15, BZ25



DMD15-13-B, DMD15-13-D



FG15-13, FG25-13



DG15-24, DG15-28



DG-1, DG-2, DG-4, DG-6, DG-8

Speed	0.01rpm-100rpm, CW/CCW
Speed resolution	0.01rpm resolution within the speed of 0.01rpm-10rpm 0.1rpm resolution within the speed of 10rpm-100rpm
Display	LCD
Control mode	Keypad control, external signal control and communication control
Work mode	Speed control mode and flow rate mode
Flow rate mode	Flow rate is displayed and the pump runs continuously at the set flow rate
Flow rate calibration	Improve the flow rate accuracy
Flow rate setting range	0.01μL/min-999L/min, unit could be set as μL/min, mL/min or L/min
External control	Start/stop control (switch signal), direction control (switch signal), speed control (0-5V, 0-10V, 4-20mA, 0-10kHz are optional with uniform interface, from 0-10rpm in 0.01rpm resolution, from 10-100rpm in 0.1rpm resolution)
Communication control	RS485 interface, Longer protocol or Modbus protocol, the communication parameters (address, baud rate, parity, stop bit) can be set through keypad
Timing function	Set the running time (13 options), the pump can run/stop automatically
Parameter memory	Operating parameters will be saved automatically
Status when powered up	The pump status when powered up can be set as stop or as the status before power loss
Prime	Fast filling or emptying at full speed
Keypad lock function	Keypad can be locked to prevent the misoperation. The delay time before lock is settable.
Dimension(L×W×H)	232×142×149(mm)
Power supply	AC100V-240V/25W, 50/60Hz
Operating temperature	0 to 40°C
Relative humidity	<80%
IP rating	IP31
Weight	2.38kg



Model (Product code)	Pump head	Tubing	Flow Rate Reference	Weight (kg)
L100-1S-2 (05.02.42A)	YZ1515x, YZII15	13" 14" 19" 16" 25" 17" 18"	0.6μL/min - 380mL/min	2.78
	YZ2515x	15" 24"	16μL/min - 270mL/min	
	YZII25	15" 24" 35" 36"	16μL/min - 500mL/min	
	FG15-13	13" 14" 19" 16" 25" 17" 18"	0.5μL/min - 430mL/min	2.66
	FG25-13	15" 24"	22μL/min - 320mL/min	
	DMD15-13-B, DMD15-13-D	2×13" 2×14" 2×19" 2×16" 2×25"	2μL/min - 375mL/min	2.81
	BZ15-13-A	14"	3μL/min - 22mL/min	
	BZ15-13-B	16"	8μL/min - 80mL/min	2.69
	BZ15-13-C	25"	16μL/min - 150mL/min	
	BZ15-13-D	17"	27μL/min - 270mL/min	
	BZ25-13-B	24"	27μL/min - 250mL/min	
	DG15-24	16" 25" 17"	8μL/min - 300mL/min(Single channel)	
	DG15-28	13" 14" ID≤3.17mm Wall Thickness 1mm	0.31μL/min - 75mL/min(Single channel)	3.05
	DG-(1,2,4,6,8)6 Rollers	ID≤3.17mm Wall Thickness 0.8-1mm	0.21μL/min - 48mL/min(Single channel)	2.58-3.01
DG-(1,2,4)10 Rollers	0.15μL/min - 32mL/min(Single channel)			

Flow Rate Peristaltic Pump

LEAD-2

PERISTALTIC PUMP



Max. Flow Rate



- Mainly used in laboratorial applications.
- Top-mounted pump head.

Pump Head Options

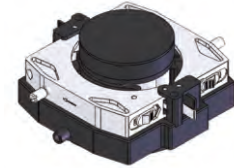

LEAD15-24
(2 channels, 4 rollers)

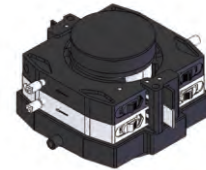

LEAD15-44
(4 channels, 4 rollers)

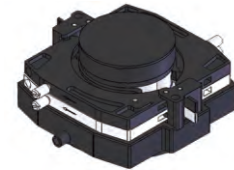

LEAD15-48
(4 channels, 8 rollers)

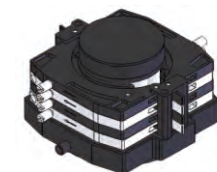

LEAD15-88
(8 channels, 8 rollers)

Speed	1rpm-100rpm, CW/CCW
Speed resolution	0.1rpm
Control mode	Control panel, external signal control and communication control are available
Display	128×32 graphic LCD for current running status
Calibration function	Improve flow rate accuracy
External control	Start/stop, direction and speed control (4-20mA, 0-5V, 0-10V, external control module optional)
Communication interface	RS485
Power-off memory	Return to previous status when powered on
Prime	For fast filling and emptying at full speed
Dimension (L×W×H)	190×162×275 (mm)
Power supply	AC 90V-260V/50W
Operating temperature	0 to 40°C
Relative humidity	<80%
IP rating	IP31
Weight	3.5kg



Model (Product code, Language)	Pump Head	Channel/rollers	Tubing	Max. Flow Rate (mL/min)	Weight (kg)
LEAD-2-A (05.02.19A, Chinese)	LEAD15-24	2/4	16" 25" 17"	300 (Single Channel)	4.36
	LEAD15-44	4/4			4.42
LEAD-2-C (05.02.19C, English)	LEAD15-48	4/8	13" 14" ID≤3.17 (mm) Wall Thickness 0.8-1 (mm)	75 (Single Channel)	4.48
	LEAD15-88	8/8			

Flow Rate Peristaltic Pump

BT100-1L

Max. Flow Rate

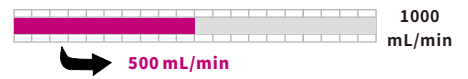

Pump Head Options



YZ1515x
YZ2515x



YZII15
YZII25



DG-2
DG-24



DG15-24
DG15-28
DG15-48



DMD15-13-B
DMD15-13-D

Speed	0.1rpm-100rpm, CW/CCW
Speed resolution	0.1rpm
Control mode	Control panel, external signal control and communication control are available
Display	128×32 graphic LCD for current running status
Calibration function	Improve flow rate accuracy
External control	Start/stop, direction and speed control (4-20mA, 0-5V, 0-10V, external control module optional)
Communication interface	RS485
Power-off memory	Return to previous status when powered on
Prime	For fast filling and emptying at full speed
Dimension (L×W×H)	202×160×239 (mm)
Power supply	AC 110V±10%/50W or AC220V±10%/50W optional
Operating temperature	0 to 40°C
Relative humidity	<80%
IP rating	IP31
Weight	5.3kg

- Mainly used in laboratorial applications.
- Can drive multi-pump heads.



PERISTALTIC PUMP

Model (Product code, Power supply)	Pump Head	Tubing	Max. Flow Rate (mL/min)	Weight (kg)
BT100-1L-A (05.02.12A, AC220V)	DG15-24	16" 25" 17"	300 (Single Channel)	6.1
	DG15-28	13" 14" ID ≤3.17 (mm) Wall Thickness 1 (mm)	75 (Single Channel)	5.9
	DG15-48			
BT100-1L-B (05.02.12B, AC110V)	DG- (2, 4, 6, 8, 12, 16, 24) 6 Rollers	ID ≤3.17 (mm)	48 (Single Channel)	5.7-8.6
	DG- (2, 4, 6, 8, 12, 16, 24) 10 Rollers	Wall Thickness 0.8-1 (mm)	32 (Single Channel)	
	(1, 2, 3, 4) × YZ1515x	13" 14" 19" 16" 25" 17" 18"	380 (Single Channel)	5.7-6.9
	(1, 2, 3, 4) × YZII15			
	(1, 2, 3, 4) × YZ2515x	15" 24"	270 (Single Channel)	
	(1, 2) × YZII25	15" 24" 35" 36"	500 (Single Channel)	5.7-6.1
(1, 2) × DMD15-13-B/DMD15-13-D	13" 14" 19" 16" 25"	350 (Single Channel)	5.7-6.1	

Dispensing Peristaltic Pump

BT100-1F

PERISTALTIC PUMP



Speed	0.1rpm-100rpm, CW/CCW
Speed resolution	0.1rpm
Control mode	Control panel, external signal control and communication control are available
Display	LCD for running status
Work mode	Flowrate mode and dispensing mode
Flowrate calibration	Improve flow rate accuracy
Dispensing volume	0.01mL-9.99L
Dispensing calibration	Calibrate dispensing volume to improve accuracy
Copy number	1 to 9999, "0" means unlimited cycle
Pause time	0.1s-99.9min, resolution is 0.1s
Back suction time	0s-99.9s, resolution is 0.1s
External control	Start/stop, direction and speed control (4-20mA, 0-5V, 0-10V, 0-10kHz external control module optional)
Speed output	10Hz-10kHz corresponding to 0.1-100rpm
Start/stop output	OC gate signal
Direction output	OC gate signal
Communication interface	RS485
Power-off memory	Return to previous status when powered on
Prime	For fast filling and emptying at full speed
Dimension (L×W×H)	285×207×180 (mm)
Power supply	AC 90V-260V/40W
Operating temperature	0 to 40°C
Relative humidity	<80%
IP rating	IP31
Weight	3.8kg

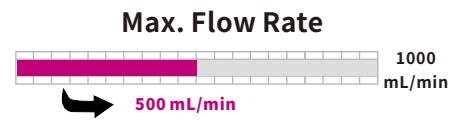

- Mainly used in laboratorial applications.

Pump Head Options



YZ1515x
YZ2515x



YZII15
YZII25



DG-1, DG-2, DG-4



DG15-24
DG15-28



DMD15-13-B
DMD15-13-D



Model (Product code, Language)	Pump Head	Tubing	Max. Flow Rate(mL/min)	Weight(kg)
BT100-1F (05.02.13A, Chinese) BT100-1F-B (05.02.13B, English)	YZ1515x, YZII15	13" 14" 19" 16" 25" 17" 18"	380	4.2
	YZ2515x	15" 24"	270	
	YZII25	15" 24" 35" 36"	500	
	DG- (1, 2, 4) 6 Rollers	ID ≤ 3.17 (mm)	48	4-4.3
	DG- (1, 2, 4) 10 Rollers	Wall Thickness 0.8-1 (mm)	32	
	DMD15-13-B, DMD15-13-D	13" 14" 19" 16" 25"	350	4.2
	DG15-24	16" 25" 17"	300 (Single Channel)	4.6
DG15-28	13" 14" ID ≤ 3.17 (mm) Wall Thickness 1 (mm)	75 (Single Channel)	4.5	

Dispensing Peristaltic Pump

BT300-1F

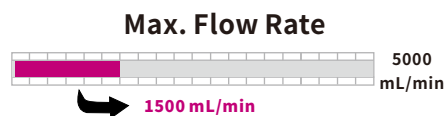

- Mainly used in laboratorial applications.

Pump Head Options



YZ1515x
YZ2515x



YZII15
YZII25



DMD15-13-B
DMD15-13-D



DG15-24

Speed	1rpm-300rpm, CW/CCW
Speed resolution	1rpm
Control mode	Control panel, external signal control and communication control are available
Display	LCD for running status
Work mode	Flowrate mode and dispensing mode
Flowrate calibration	Improve flow rate accuracy
Dispensing volume	0.1mL-99.9L
Dispensing calibration	Calibrate dispensing volume to improve accuracy
Copy number	0 to 65000, "0" means unlimited cycle
Pause time	0.1s-999s (0.1s resolution within the time of 0.1s-100s, 1s resolution within the time of 100s-999s.)
Back suction angle	0-360°, resolution is 18°
External control	Start/stop, direction and speed control (4-20mA, 0-5V, 0-10V, external control module optional)
Speed output	0-5V corresponding to 1-300rpm
Start/stop output	OC gate signal
Direction output	OC gate signal
Communication interface	RS485
Power-off memory	Return to previous status when powered on
Prime	For fast filling and emptying at full speed
Dimension (L×W×H)	202×160×239 (mm)
Power supply	AC 220V±10%/50W or AC 110V±10%/50W
Operating temperature	0 to 40°C
Relative humidity	<80%
IP rating	IP31
Weight	4.3kg



Model (Product code, Power supply, Language)	Pump Head	Tubing	Max. Flow Rate(mL/min)	Weight(kg)
BT300-1F-A(05.02.32A, AC220V, Chinese)	YZ1515x, YZII15	13" 14" 19" 16" 25" 17" 18"	1140	4.7
	YZ2515x	15" 24"	840	
BT300-1F-B(05.02.32B, AC110V, Chinese)	YZII25	15" 24" 35" 36"	1500	
BT300-1F-C(05.02.32C, AC220V, English)	DMD15-13-B, DMD15-13-D	13" 14" 19" 16" 25"	1040	4.7
BT300-1F-D(05.02.32D, AC110V, English)	DG15-24	16" 25" 17"	900 (Single Channel)	5.1

Dispensing Peristaltic Pump

WT600-1F

PERISTALTIC PUMP



Flow Rates



- Mainly used in laboratorial applications.
- With brushless motor, can drive multi-pump heads.

Pump Head Options



YZ1515x
YZ2515x



YZ1115
YZ1125



KZ25



DMD15-13-B
DMD15-13-D



DG15-24

Speed	10rpm-600rpm, CW/CCW
Speed resolution	1rpm
Control mode	Control panel, external signal control and communication control are available
Display	LCD for running status
Work mode	Flowrate mode and dispensing mode
Flowrate calibration	Improve flow rate accuracy
Dispensing volume	0.1mL-99.9L
Dispensing calibration	Calibrate dispensing volume to improve accuracy
Copy number	1 to 9999, "0" means unlimited cycle
Pause time	0.1s to 99.9min, resolution is 0.1s
Back suction circle	0 to 9.9 circle, resolution is 0.1 circle
External control	Start/stop, direction and speed control (4-20mA, 0-5V, 0-10V, 0-10kHz external control module optional)
Speed output	166.7Hz-10kHz corresponding to 10-600rpm
Start/stop output	OC gate signal
Direction output	OC gate signal
Communication interface	RS485
Power-off memory	Return to previous status when powered on
Prime	For fast filling and emptying at full speed
Dimension (L×W×H)	285×207×180 (mm)
Power supply	AC 220V±20%/140W or AC 110V±20%/140W
Operating temperature	0 to 40°C
Relative humidity	<80%
IP rating	IP31
Weight	5.2kg



Model (Product code, Power supply)	Pump Head	Tubing	Flow Rate(mL/min)	Weight(kg)
WT600-1F-A (05.02.65A, AC220V)	(1, 2, 3)×YZ1515x	13" 14" 19" 16" 25" 17" 18"	0.7-2200 (Single Channel)	5.6-6.4
	(1, 2, 3)×YZ1115			
	(1, 2, 3)×YZ2515x	15" 24"	17-1600 (Single Channel)	
WT600-1F-B (05.02.65B, AC110V)	(1, 2)×YZ1125	15" 24" 35" 36"	17-3000 (Single Channel)	5.6-6.0
	DG15-24	16" 25" 17"	8-1800 (Single Channel)	6.0
	(1, 2)×DMD15-13-B/DMD15-13-D	13" 14" 19" 16" 25"	1.5-2070 (Single Channel)	5.6-6.0
	KZ25	15" 24" 35" 36"	34-6000	6.0

Dispensing Peristaltic Pump

WT600-4F

Flow Rates

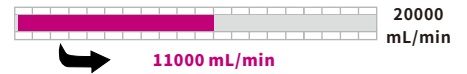

- Mainly used in laboratorial and industrial applications.
- With brushless motor, can drive multi-pump heads.
- Aluminum alloy housing, high IP rating.



PERISTALTIC PUMP

Pump Head Options



YZ35-13



KZ35

Speed	10rpm-600rpm, CW/CCW
Speed resolution	1rpm
Control mode	Control panel, external signal control and communication control are available
Display	LCD for running status
Work mode	Flowrate mode and dispensing mode
Flowrate calibration	Improve flow rate accuracy
Dispensing volume	100mL-999L
Dispensing calibration	Calibrate dispensing volume to improve accuracy
Copy number	1 to 9999, 0 means unlimited cycle
Pause time	0.1s to 99.9min, resolution is 0.1s
Back suction circle	0 to 9.9 circle, resolution is 0.1 circle
External control	Start/stop, direction and speed control (4-20mA, 0-5V, 0-10V, 0-10kHz external control module optional)
Speed output	125Hz-7.5kHz corresponding to 10-600rpm
Start/stop output	OC gate signal
Direction output	OC gate signal
Communication interface	RS485
Power-off memory	Return to previous status when powered on
Prime	For fast filling and emptying at full speed
Dimension (L×W×H)	360×215×243(mm)
Power supply	AC110V±20%/300W or AC220V±20%/300W
Operating temperature	0 to 40°C
Relative humidity	<100%
IP rating	IP65
Weight	12kg

Model (Product code, Power supply, Speed control signal)	Pump Head	Tubing	Speed (rpm)	Flow Rate(mL/min)	Weight(kg)
WT600-4F-A (05.02.66A, AC220V, 0-5V)	(1, 2) x YZ35-13-B	73#, 82#	10-600	100-11000	13.65-15.3
WT600-4F-B (05.02.66B, AC220V, 0-10V)	(1, 2) x YZ35-13-D	73#, 82#	10-600	100-11000	
WT600-4F-C (05.02.66C, AC220V, 4-20mA)	(1, 2) x YZ35-13-D	82A#	10-300	267-8000	
WT600-4F-D (05.02.66D, AC220V, 0-10kHz)	(1, 2) x YZ35-13-D	82A#	10-300	267-8000	
WT600-4F-E (05.02.66E, AC220V, RS485)	(1, 2) x YZ35-13-F	26#	10-600	67-4000	15.7-19.4
WT600-4F-F (05.02.66F, AC110V, 0-5V)	(1, 2) x YZ35-13-F	26#	10-600	67-4000	
WT600-4F-G (05.02.66G, AC110V, 0-10V)	(1, 2) x KZ35-13-B	26#, 73#, 82#	10-600	67-11000	
WT600-4F-H (05.02.66H, AC110V, 4-20mA)	(1, 2) x KZ35-13-D	26#, 73#, 82#	10-600	67-11000	
WT600-4F-I (05.02.66I, AC110V, 0-10kHz)	(1, 2) x KZ35-13-D	26#, 73#, 82#	10-600	67-11000	
WT600-4F-J (05.02.66J, AC110V, 0-10kHz)	(1, 2) x KZ35-13-D	26#, 73#, 82#	10-600	67-11000	15.7-19.4
WT600-4F-K (05.02.66K, AC110V, RS485)	(1, 2) x KZ35-13-D	82A#, 184#	10-300	267-9000	

Industrial Peristaltic Pump

参考流量范围

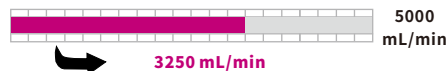

G100-1L, G300-1L, G600-1L



- Die-cast aluminum housing with powder coat for good corrosion protection
- Waterproof breathable design, enhanced sealing performance, IP66 protection for wet and dusty environment
- Multiple work modes: continuous transfer, timed transfer, volume transfer, for various applications

IP66 CE UK CA

PERISTALTIC PUMP

	G100-1L	G300-1L	G600-1L
Product code	05.02.24A	05.02.25A	05.02.26A
Speed range	0, 0.01-150 (rpm)	0, 0.01-350 (rpm)	0, 0.01-650 (rpm)
Speed resolution	0.01rpm(< 10rpm)	0.1rpm(10rpm ≤ speed < 100rpm)	1rpm(100rpm ≤ speed ≤ Max speed)
Flow rate range	0.15uL/min-750mL/min	0.15uL/min-1750mL/min	0.15uL/min-3250mL/min
Display	LCD for speed, flow rate, running time, dispensed volume, and other setting parameters		
Work mode	continuous transfer, timed transfer, volume transfer		
Calibration	Improve the flow rate and dispensing volume accuracy		
Control mode	Keypad control, footswitch control, external signal control and communication control		
External control	Start/stop control, direction control: logic level signal or switch signal (dry contact), momentary or maintained trigger mode can be configured Speed control: 0-5V/0-10V/4-20mA/0-10kHz with uniform interface, speed range/signal range can be configured		
Communication control	RS485 interface, Modbus RTU and Longer Pump OEM protocol, communication parameters can be configured		
Keypad lock	Keypad can be locked to prevent misoperation, the delay time before lock can be configured		
Parameter memory	Running parameters and system parameters can be saved automatically		
Pump status when powered up	The pump status when powered up can be set to stop or the status before power-off		
Prime	Fast filling or emptying at full speed		
Certificate	CE, UKCA EMC: EN IEC61000-6-2:2019 EN IEC61000-6-4:2019 LVD: EN 61010-1:2010/A1:2019 EN 61010-1:2010/A1:2019		
Dimension (LxWxH)	240*142*152(mm)		
Power supply	AC100-240V 50Hz/60Hz		
Power consumption	25W	40W	60W
Working condition	Environment temperature: 0°C-40°C, relative humidity: 10%-90%		
IP rating	IP66		
Weight	3.64kg	3.75kg	3.75kg

Pump Head	Tubing	Max Flow Rate Reference (mL/min)		
		G100-1L	G300-1L	G600-1L
dPOFLEX® BPH01	13#,14#,19#,16#,25#	130	300	530(@600rpm intermittent)
YZ1515x, YZ1115	13#,14#,19#,16#,25#,17#,18#	570	1280	2380
YZ2515x	15#, 24#	400	930	1730
YZ1125	15#, 24#, 35#, 36#	750	1750	3250
FG15-13	13#,14#,19#,16#,25#,17#,18#	645	1400	2600
FG25-13	15#, 24#	480	1280	2380
DMD15-13	2x13#, 2x14#, 2x19#, 2x16#, 2x25#	560	1200	2500
DG15-24	16#, 25#, 17#	450(single channel)	1050(single channel)	1900(single channel)
DG15-28	13#,14# ID≤ 3.17mm,wall thickness:1mm	75 (single channel, speed≤100rpm)		
DG-(1,2,4,6,8) 6 rollers	ID≤ 3.17mm Wall thickness:0.8-1mm	48 (single channel, speed≤100rpm)		
DG-(1,2,4) 10 rollers	ID≤ 3.17mm Wall thickness:0.8-1mm	32 (single channel, speed≤100rpm)		

dPOFLEX® Industrial Peristaltic Pump

GP01, BP01

Max. Flow Rate:

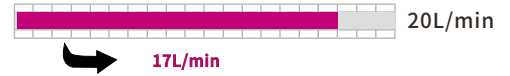

- Available in stainless steel housing and cast aluminum housing for variety of applications
- IP66 for wet and dusty environment
- Supports fieldbus communication control, digital signal control, analog signal control, and pump status output
- Three-level user authority management, with electronic signature and audit trail functions, meets 21CFR Part 11 and GMP requirements
- Integrates multiple sensors: fluid leakage sensor, open-head sensor and flowrate sensor, to support predictive maintenance

PERISTALTIC PUMP

Pump drive model	dPOFLEX GP01	dPOFLEX BP01
Housing material	Cast aluminum	304sst
Speed range	0.1rpm-265rpm, CW/CCW	
Speed resolution	0.1rpm	
Display	4.3 inch LCD, Chinese or English	
Clock function	Year/month/day/hour/minute can be set, hours and minutes are displayed on the running screen	
Work mode	Flow rate mode, dispensing mode, calibration mode	
Flow rate mode	Pump runs continuously at the set flow rate, and displays flow rate and pump speed on the screen	
Flow rate setting range	1.1ml/min-17.0L/min depending on pump head and tubing	
Dispensing mode	Pump repeats the dispensing at set volume, cycles and interval time, and displays single volume, dispensed volume, dispensed cycles/target cycles on screen	
Volume of single dispense	1.0mL-274.9L depending on pump head and tubing	
Dispensing cycles	1-9999 (0 for unlimited)	
Interval time	5s-9999s	
Calibration function	Improve the flow rate and dispensing volume accuracy	
Control mode	Keypad control, foot switch control, external signal control and communication control	
Communication control	Standard:RS485 and Industrial Ethernet Interface, Modbus RTU and TCP/IP protocol, Optional: Profibus DP	
External control	Speed control: 0-10V, 4-20mA Start/stop, direction control: 5V-24V logic level signal or relay signal (dry contact)	
Status output	Pump Speed: 0-10V, 4-20mA, frequency signal Running/stop, direction, tubing leak alarm/other alarm: 3 relay signal (dry contact)	
Open head sensor	Pump will stop when pump head is open for enhanced user safety	
Status when power up	Stop	
Keypad lock function	Enable the keypad lock function to lock the keypad automatically after 20s standby, (start/stop key will not be locked)	
Tubing leak detection	Detect the tubing leak and give alarm (optional)	
Flow rate measurement	Measure the flow rate by connecting flow meter (optional)	
User access control	Three levels of user accesses (administrator, technician, operator)	
Electronic signature and audit trail	Meet the requirement of FDA 21CFR Part 11	
Log record	Record 90 days operation history, and can be exported directly	
3Q verification	IQ/OQ	
Certificate	CE, UKCAEN 61010-1:2010 EN IEC 61010-2-201 EMC EN IEC61000-6-2 EN IEC 61000-6-4	
Dimension (LxWxH)	260x407x298mm	260x407x290mm
Power supply	AC100-240V 50/60Hz,250W	
Operating condition	Temperature: 5°C-40°C, relative humidity≤100%	
IP rating	IP 66	
Weight (drive only)	≤17.6kg	≤16.6kg

BP01+LPH01

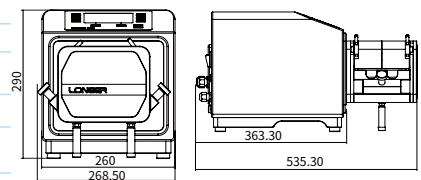

BP01+GPH01

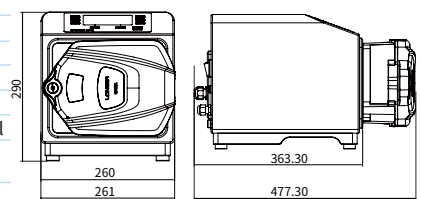

GP01+LPH01

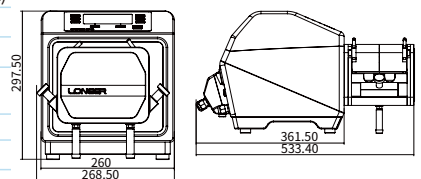

GP01+GPH01

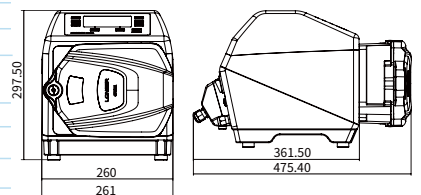

Model (Product Code)	Pump Head	Roller Number	Tubing	Reference Max. Flow Rate (L/min)
dPOFLEX GP01 (05.02.80A) dPOFLEX BP01 (05.02.81A)	GPH01	2	26#, 73#, 82#,184#	15
	GPH02	2	186#,188#	17
	GPH03	4	186#,188#	14
	LPH01	6	185#, 186#, 187#	13.5

dPOFLEX® Industrial Peristaltic Pump

GP02, BP02

Max. Flow Rate:



- Available in stainless steel housing and cast aluminum housing for a variety of applications
- IP66 for wet and dusty environment
- Supporting fieldbus communication control, digital signal control, analog signal control, and pump status output
- Three-level user access management, with electronic signature and audit trail functions, meets FDA 21CFR Part 11 requirements
- Various sensors: tubing compressed detection, actual flow rate measurement, fluid pressure measurement, for predictive maintenance

PERISTALTIC PUMP

Pump drive model	dPOFLEX GP02	dPOFLEX BP02
Housing material	Cast aluminum	304sst
Speed range	1rpm-300rpm, CW/CCW	
Speed resolution	0.1rpm	
Display	3.5 inch LCD, Chinese or English	
Clock function	Clock can be set for log record, and displayed on the running screen	
Work mode	Flow rate mode, dispensing mode, calibration mode	
Flow rate mode	Pump runs continuously at the set flow rate, and displays flow rate and pump speed on the screen	
Flow rate setting range	1.0mL/min-9.0L/min (depends on pump head and tubing)	
Dispensing mode	Pump repeats the dispensing at set volume, cycles, interval time and back suction parameter, and displays single volume, total volume, dispensed cycles/target cycles on screen	
Volume of single dispense	1.0mL-225L (depends on pump head and tubing)	
Dispensing cycles	1-9999 and unlimited	
Interval time	1s-9999s	
Calibration function	Improve the flow rate and dispensing volume accuracy	
Control mode	Keypad control, external signal control, communication control and foot switch control	
Communication control	Interface: RS485, Profibus(optional) Protocol: Modbus RTU, Profibus DP(optional)	Interface: RS485, Industrial Ethernet(optional) or Profibus(optional) Protocol: Modbus RTU, Modbus TCP/IP(optional), Profibus DP (optional)
External control	Speed control signal: 0-5V, 0-10V, 0-10kHz, 4-20mA Start/stop, direction control: 5V-24V logic level signal or relay signal (dry contact)	
Status output	Running/stop, fault status: relay signal (dry contact)	Pump Speed: frequency signal Running/stop, fault status: relay signal (dry contact)
Compressed tubing detection	Pump will automatically stop when it detects the tubing is not compressed well, and an alarm message will be promoted. The function can be enabled and disabled.	
Actual flow rate measurement	Measure and display the flow rate by connecting ultrasonic flow meter (optional)	
Fluid pressure measurement	Measure and display the fluid pressure inside the tubing by connecting pressure sensor (optional)	
Pump status when power on	Pump stops or runs in the flow rate mode. Pump stops in the dispensing mode	
Keypad lock function	Enable the keypad lock function to lock the keypad automatically after 20s standby, (start/stop key will not be locked)	
User access control	Three levels of user accesses (administrator, technician, operator)	
Electronic signature and audit trail	Meets the requirement of FDA 21CFR Part 11	
Log record	Record 90 days operation Logs, and can be exported directly	
Support IQ/OQ	Meet GMP requirement	
Certificate	CE, UKCA EN 61010-1:2010, EN IEC 61010-2-201; EMC EN IEC61000-6-2, EN IEC 61000-6-4	
Dimension(LxWxH)	215 x 358 x 243mm (drive only)	215 x 362 x 258mm (drive only)
Power supply	AC100-240V/115W 50/60Hz	
Operating condition	Temperature: 5°C-40°C, relative humidity≤100%	
IP rating	IP66	
Weight (drive only)	≤10.4kg	≤10.5kg

BP02+KZ35

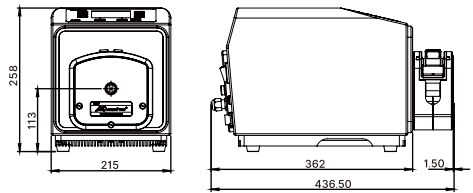

BP02+YZ35

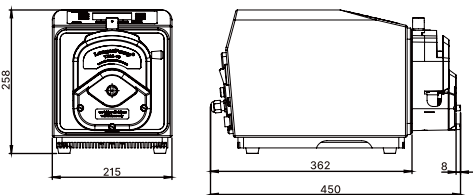

GP02+KZ35

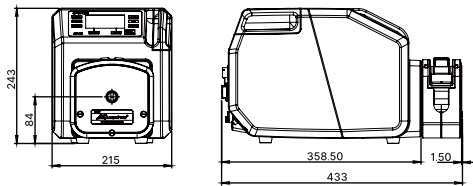

GP02+YZ35

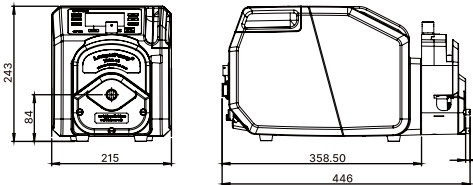

Product Model(Product Code)	Pump Head	Roller Number	Tubing	Reference Max. Flow Rate (L/min)
dPOFLEX GP02 (05.02.83A) dPOFLEX BP02 (05.02.84A)	YZ35-13	3	26#	2
			73#	4
			82#	6.5
			82A#	8
			26#	2
	KZ35-13	3	73#	4
			82#	6.5
			82A#	8
			184#	9
			184#	9

dPOFLEX® Explosion Proof Motor Pump

EP01

Max. Flow Rate:



- Explosion proof motor
- Frequency Converter (Optional) to be used outside the hazardous location
- IP55 protection
- Explosion proof design pump heads with high flow rate up to 17L/min

Pump Drive	Pump speed	23rpm-265rpm
	Housing material	Cast iron (304ss protective cover is optional)
	Control mode	Frequency converter (to be used outside the hazardous location)
	Protection type	Ex d IIB T4 Gb
	Dimension (L*W*H)	765x300x400mm (without pump head)
	Power supply	3-phase AC 380V, 5Hz-60Hz
	Rated power	0.75kW
	Frequency range	5Hz-60Hz
	Working condition	5-40°C, relative humidity ≤90% RH
	IP rating	IP55
	Weight	60kg (without pump head and 304ss cover)
Frequency Converter (Optional)	1-phase converter	Model: VFD4A8MS21ANSAA, Input: 1-phase AC220V
	3-phase converter	Model: VFD2A7MS43ANSAA, Input: 3-phase AC380V
	Running direction	CW or CCW
	Speed resolution	0.01Hz (based on the output frequency resolution of the converter)
	Control mode	Keypad control, remote control and communication control
	Display	Segment LED display
	External control	Output frequency could be controlled by analog signal: 0-10V, 0-20mA, 4-20mA; Manual/remote control mode, pump running direction, pump start/stop, could be controlled by digital signal
	Status output	Output 0-20mA or 4-20mA to indicate the frequency to pump; Output relay signal to indicate pump status such as running/stop, direction or alarm
Communication control	Rs485 interface, Modbus RTU protocol	

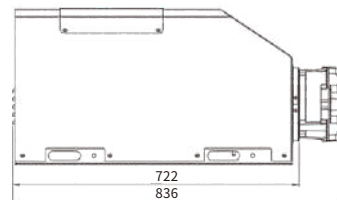
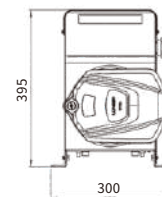
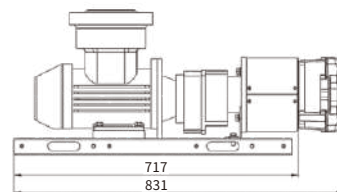
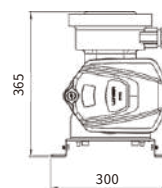

PERISTALTIC PUMP

Pump Model (Product Code)	Pump Head	Roller Number	Tubing	Reference Max Flow Rate (L/min)
dPOFLEX EP01 (05.02.82A)	GPH01-1	2	26#, 73#, 82#, 184#	15
	GPH02-1	2	186#, 188#	17
	GPH03-1	4	186#, 188#	14

dPOFLEX® Explosion Proof Motor Pump

EP02 ,EP02-B

PERISTALTIC PUMP



- Explosion proof AC motor: Ex d IIB T4 Gb
- Using frequency converter outside the hazardous location
- Motor with IP55 protection
- Could be mounted with several different pump heads, single pump head or stacked pump heads
- A wide range of flow rate: 4mL/min-12,000mL/min

Pump Drive	Product model	dPOFLEX EP02	dPOFLEX EP02-B
	Housing material	Cast iron	304ss protective cover
	Pump speed	60rpm-600 rpm	
	Control mode	Frequency converter (to be used outside the hazardous location)	
	Protection type	Ex d IIB T4 Gb	
	Power supply	3-phase AC 380V, or 3-phase AC 220V	
	Frequency range	5Hz-60Hz	
	Dimension (LxWxH)	414×292×340mm (without pump head)	424×292×352mm (without pump head)
	Rated power	0.18kw	
	IP rating	IP55	
	Working condition	Temperature: 5 - 40°C, Relative humidity ≤90%RH	
	Weight	About 40kg (without pump head)	About 45kg (without pump head)
	Frequency Converter (Optional)	1-phase converter	Model: VFD4A8MS21ANSAA, input: 1-phase AC220V
3-phase converter		Model: VFD2A7MS43ANSAA, input: 3-phase AC380V	
Running direction		CW / CCW	
Speed resolution		0.01Hz	
Display		LED	
Control mode		Keypad control, remote control and communication control	
External control		Output frequency could be controlled by analog signal: 0-10V, 0-20mA, 4-20mA; Manual/remote control mode, pump running direction, pump start/stop, could be controlled by digital signal	
Status output		Output 0-20mA or 4-20mA to indicate the frequency to pump; Output relay signal to indicate pump status such as running/stop, direction or alarm	
Communication control	RS485 interface, Modbus RTU protocol		

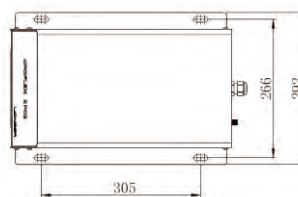
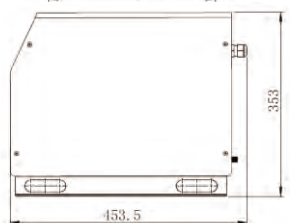
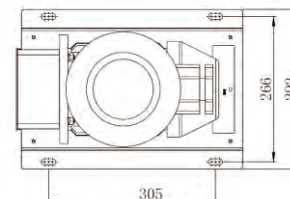
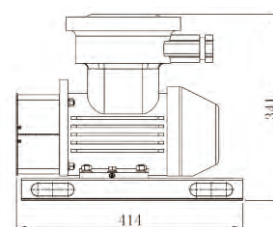

Product Model (Product Code)	Pump Head	Tubing	Reference Flow Rate (mL/min)
dPOFLEX EP02 (05.02.85A) dPOFLEX EP02-B (05.02.85B)	(1, 2, 3, 4) x YZ1515x (3 rollers)	13#, 14#, 19#, 16#, 25#, 17#, 18#	4-2200
	(1, 2, 3, 4) x YZ1515x (6 rollers)	13#, 14#, 19#, 16#, 25#, 17#, 18#	4-1450
	(1, 2, 3, 4) x YZ1115	13#, 14#, 19#, 16#, 25#, 17#, 18#	4-2200
	(1, 2, 3, 4) x YZ2515x	15#, 24#	100-1600
	(1, 2, 3, 4) x YZ1125	15#, 24#, 35#, 36#	100-3000
	(1, 2) x KZ25	15#, 24#, 35#, 36#	200-6000

Syringe Pump ■ Series

dLSP 501X Series Digital Split-type Syringe Pump

dLSP 501S, dLSP 501L, dLSP 501W

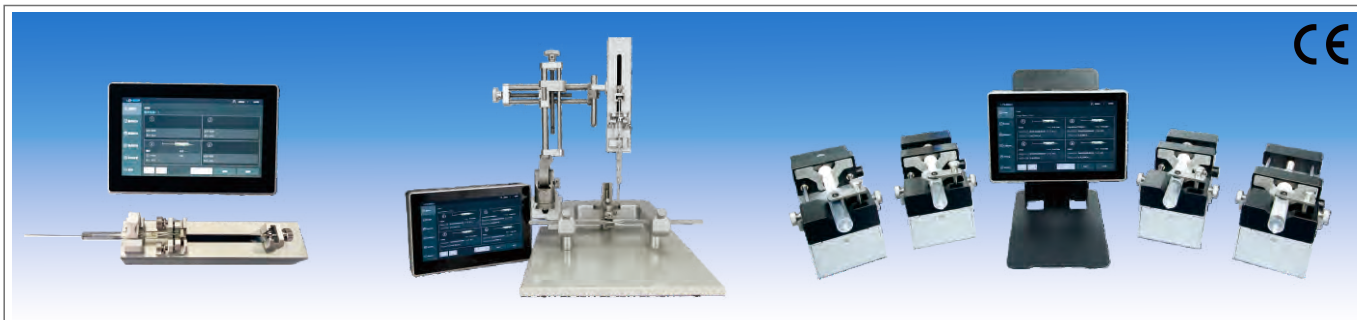

SYRINGE PUMP

Product model	Drive unit	dLSP 501S	dLSP 501L	dLSP 501W
	Controller	dLSP uC		
Control mode	Touch screen controller	Control 1-4 separated drive units with preset parameters through touch screen controller		
	Computer	Dedicated PC control software can control 10 drive units independently		
	PLC/ other controller	RS485 interface, Modbus RTU, can control 40 drive units independently		
Display		7 inch HD LCD		
Work mode		Infusion only, withdrawal only, infusion/withdrawal, withdrawal/infusion, programming (on PC software)		
Stroke of the drive unit		70mm	70mm	95mm
Pusher advance per microstep		0.095um/ustep	0.099um/ustep	0.098um/ustep
Linear speed		0.6096um/min-182.88mm/min	0.635um/min-190.5mm/min	0.625um/min-143.75mm/min
Linear speed resolution		0.6096um/min	0.635um/min	0.625um/min
Linear travel accuracy		≤ ±0.35%(when travel ≥ 30% of the stroke)		
Linear travel CV		0.03% (rated travel)		
Linear force (Max.)		15N (can be set 20%-100%)	30N (can be set 20%-100%)	100N (can be set 20%-100%)
Syringe (built-in manufacturer, or user-defined)		0.5uL-250uL	0.5uL-1000uL	5uL-60mL
Flow rate calibrate		Calibrate the user-defined syringe for better flow rate /dispensing volume accuracy and precision		
Parameter method		Up to 100 parameter methods can be stored on the controller, and can be imported/exported to USB flash drive		
Programming function		Parameter configured based on workflow on PC.PC method programmer:infusion,withdrawal,delay,repeat. PC control software: constant flow rate, ramp up/down, delay, repeat.		
Screen lock		Prevent misoperation		
User access control		Three levels of user access (administrator, developer, operator), each user can have an exclusive password		
Log record		Record the pump operation history, and can be exported to a USB flash drive		
Electronic signature		There are electronic signatures on the log record for FDA 21CFR Part11 compliance		
Pump state when powered up		The default state is stop, can be set to continue to run through communication commands		
Fast forward/backward		Infuse or withdraw liquid at full speed		
Controller dimensions (LxWxH)		187mm*123mm*39mm		
Controller weight		0.6kg		
Power supply for controller		AC 90V-260V/30W		
Drive unit dimensions (LxWxH)		170mm*35mm*58mm	180mm*45mm*74mm	235mm*103mm*91mm
Drive unit weight		0.31kg	0.51kg	1.65kg
Power supply for drive unit		DC 24V/2W	DC 24V/3.6W	DC 24V/7.5W

- Remote pump drive unit with compact structure and small footprint, ideal for hand-held or clamping devices
- High precision and pulseless delivery, suitable for small liquid volume transfer and handling

dLSP 501S

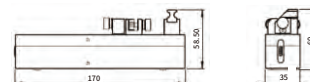

dLSP 501L

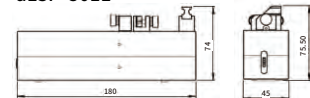

dLSP 501W

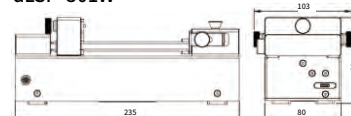

dLSP uC Controller

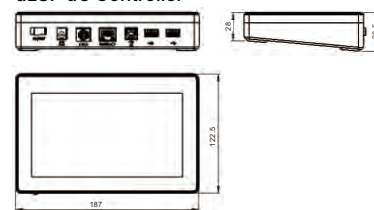

Syringe (uL)	Syringe ID(mm)	dLSP 501S	dLSP 501L	dLSP 501W
0.5uL	0.10	0.0048nL/min-1.435uL/min	0.0050nL/min-1.495uL/min	-
1uL	0.15	0.0108nL/min-3.230uL/min	0.0112nL/min-3.365uL/min	-
2uL	0.20	0.0191nL/min-5.742uL/min	0.0199nL/min-5.982uL/min	-
5uL	0.35	0.0586nL/min-17.59uL/min	0.0611nL/min-18.32uL/min	0.0601nL/min-13.82uL/min
10uL	0.50	0.1196nL/min-35.89uL/min	0.1246nL/min-37.39uL/min	0.1227nL/min-28.21uL/min
25uL	0.80	0.3063nL/min-91.88uL/min	0.3190nL/min-95.71uL/min	0.3140nL/min-72.22uL/min
50uL	1.10	0.5790nL/min-173.7uL/min	0.6032nL/min-180.9uL/min	0.5937nL/min-136.5uL/min
100uL	1.46	1.020nL/min-306.0uL/min	1.063nL/min-318.8uL/min	1.046nL/min-240.5uL/min
250uL	2.30	2.531nL/min-759.4uL/min	2.637nL/min-791.1uL/min	2.595nL/min-596.9uL/min
500uL	3.25	-	5.265nL/min-1580uL/min	5.182nL/min-1192uL/min
1000uL	4.61	-	10.594nL/min-3178uL/min	10.43nL/min-2398uL/min
2mL	9.00	-	-	39.74nL/min-9.140mL/min
5mL	13.10	-	-	84.20nL/min-19.37mL/min
10mL	16.60	-	-	135.2nL/min-31.10mL/min
20mL	19.00	-	-	177.1nL/min-40.74mL/min
30mL	23.00	-	-	259.5nL/min-59.69mL/min
60mL	29.14	-	-	416.6nL/min-95.82mL/min

Laboratorial Syringe Pump

dLSP 500 Series

Max. Flow Rate



- Dedicated PC software and Android App permit remote control and monitoring
- Intelligent diagnosis and voice reminder for working progress and pump status
- High precision and stable fluid delivery with good EMC performance, ideal for microfluidic and electrospinning applications
- 7 inch full touch screen with intuitive graphic interface for fantastic interactive experience
- Custom parameters can be configured quickly, and be stored and easily recalled
- User can access control and log record for safety management. With the electronic signature function for FDA (21CFR Part 11) compliance



	dLSP 510	dLSP 520	dLSP 540*	dLSP 5A0*	dLSP 510 Pro	dLSP 520 Pro
Work mode	Infusion only, withdrawal only, infusion/withdrawal, withdrawal/ infusion, auto repeated, programming (on dedicated PC software)					
Number of channel	1	2	4	10	1	2
Pusher advance per microstep	0.03255µm/µstep			0.015625µm/µstep		
Linear speed	0.0833µm/min-180mm/min			0.04µm/min-86.4mm/min		
Step speed	23.4375 sec/µstep-10.85 µsec/µstep					
Linear travel accuracy (Rated)	±0.5%			±0.35%		
Linear travel CV(Rated)	±0.05%					
Linear force (Rated)	Rated thrust 40lbs/18kg adjustable thrust					
Motor and drive	1.8° step motor with 1/64 microstepping					
Syringe	0.5uL-60mL	0.5uL-30mL	0.5uL-20mL	0.5uL-10mL	0.5uL-60mL	0.5uL-30mL
User-defined syringe	Travel≤108mm, OD≤31.5mm	Travel≤108mm, OD≤26mm	Travel≤108mm, OD≤22mm	Travel≤108mm, OD≤18mm	Travel≤108mm, OD≤31.5mm	Travel≤108mm, OD≤26mm
Display	7 Inch, 1024x600, IPS HD LCD					
Language	Chinese or English, set as needed					
Control mode	Touch screen control, dedicated PC or Android App control, footswitch control, RS485 communication control					
Interface	RS485(optional), USB-B,USB-A,Wifi, bluetooth, Ethernet, footswitch 3 outputs- solid state relay signal, 2 inputs-switch signal or TTL signal, 4-20mA signal(optional)					
Wireless connectivity(optional)	Wifi, bluetooth					
Programming function	Parameter configured based on work flow: constant, ramp, loop, delay, repeat, I/O output trigger, I/O event input trigger, touch screen trigger					
Calibration	Improve flow rate/ dispensing volume precision and accuracy					
Parameter method	Parameter methods can be stored and easily recalled					
Real time clock	Date and time can be set					
Audible alarm	For keypad clicks, end of run, near end of run, power on, motor stall, etc.					
Voice reminder	For working progress, alarm, diagnosis					
Intelligent diagnosis	N/A			For presence of syringes, syringe leakage		
Screen lock	To prevent misoperation					
User access control	Three levels of user accesses(administrator, developer, operator), in line with safety management requirement(21CFR Part 11)					
Log record	Record the complete operation history of the pump, and can be exported directly					
Electronic signature and audit trail	Meet the requirement of 21CFR Part 11 (on dedicated PC software)					
Support 3Q(IQ/OQ/PQ)	Meet GMP requirement					
EMC	CE (TUV) certified					
Dimension(L×W×H)	Drive unit: 260mm×185mm×180mm, Controller: 190mm×123mm×33mm					
Power supply	AC 100V-240V/30W 50/60Hz			AC 100V-240V/20W 50/60Hz		
Operating condition	Temperature: 5°C-40°C, Relative humidity<85%					
IP rating	IP31					
Controller weight	0.4kg					
Pump drive weight	3.5kg		3.7kg	4kg		3.5kg

Product Model		dLSP 510/dLSP 520/dLSP 540/dLSP 5A0	dLSP 510 Pro/dLSP 520 Pro
Syringe	Syringe ID (mm)	Reference flow rate (nL/min-mL/min)	
0.5ul	0.1	0.0007nL/min-0.0014mL/min	0.0003nL/min-0.0007mL/min
5ul	0.35	0.008nL/min-0.017mL/min	0.004nL/min-0.008mL/min
10ul	0.5	0.016nL/min-0.035mL/min	0.008nL/min-0.017mL/min
25ul	0.8	0.042nL/min-0.090mL/min	0.020nL/min-0.043mL/min
50ul	1.1	0.079nL/min-0.171mL/min	0.038nL/min-0.082mL/min
100ul	1.6	0.167nL/min-0.362mL/min	0.080nL/min-0.174mL/min
500ul	3.25	0.691nL/min-1.493mL/min	0.332nL/min-0.717mL/min
1ml	4.72	1.458nL/min-3.150mL/min	0.700nL/min-1.512mL/min
2ml	9	5.299nL/min-11.451mL/min	2.545nL/min-5.497mL/min
5ml	13.1	11.227nL/min-24.261mL/min	5.391nL/min-11.645mL/min
10ml	16.6	18.028nL/min-38.956mL/min	8.657nL/min-18.699mL/min
20ml	19	23.618nL/min-51.035mL/min	11.341nL/min-24.497mL/min
30ml	23	34.609nL/min-74.786mL/min	16.619nL/min-35.897mL/min
60ml (510 series)	29.14	55.554nL/min-120.044mL/min	26.677nL/min-57.621mL/min

*product is in the process of certification

Laboratorial Syringe Pump

ASP100 Series Digital Syringe Pump

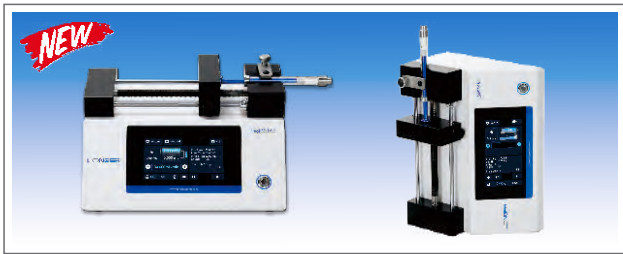

- Experience unmatched ease of use with a high-resolution color LCD and an intuitive full-touchscreen interface.
- Delivering liquids with exceptional accuracy and a pulseless flow, perfect for handling small volumes.
- Fine-tune the flow rate in real time, optimizing the pump parameters even while in operation.
- Provided with ready-to-use Labview drivers and demos for streamlined automation and effortless integration with other lab equipment.



SYRINGEPUMP

Product Model	ASP11-1A	ASP11-1AP	ASP11-2AP	ASP12-1B	ASP12-2B
Work mode	Single infuse, multiple infuse			Single infuse, multiple infuse, single withdraw, infuse/withdraw(Continuous), withdraw/infuse(Continuous)	
Number of syringes	1	1	2	1	2
Syringe options	0.5 μ L-60mL			0.5 μ L-150mL	
Flow rate for reference	3.3pL/min-120.0mL/min		0.9pL/min-29.5mL/min	3.3pL/min-226.0mL/min	
Stroke	110mm			140mm	
Pusher advance per microstep	0.0326 μ m/microstep	0.0088 μ m/microstep		0.0326 μ m/microstep	
Linear speed	0.416 μ m/min-180mm/min	0.1126 μ m/min-35.4mm/min		0.416 μ m/min-180mm/min	
Linear speed resolution	0.416 μ m/min	0.1126 μ m/min		0.416 μ m/min	
Linear travel accuracy	$\leq \pm 0.35\%$ (When travel $\geq 30\%$ of stroke)				
Linear travel CV	CV $\leq 0.03\%$ (When travel $\geq 30\%$ of stroke)				
Linear force (Max.)	320N(Can be set 20%-100%)				
Built-in syringe	Common syringe brands and models on the market				
User-defined syringe	Store 20 user-defined syringes: travel ≤ 110 mm, 6.75mm \leq OD ≤ 31 mm			Store 20 user-defined syringes: travel ≤ 140 mm, 6.75mm \leq OD ≤ 43 mm	
Calibration	Improve flow rate/ volume precision and accuracy by calibrating the user-defined syringe				
Display	4.3 inch LCD for parameters and pump status				
Parameter method	20 parameter methods can be stored and easily recalled				
Control mode	Touchscreen control, external control, communication control, footswitch control, Labview control				
External control	Two control inputs: switch signals or level signals for start/stop and emergency stop Two status outputs: can be configured as start/stop, direction or fault alarm				
Communication control	RS485, Modbus RTU or Longer OEM protocol				
Real-time adjustment	The flow rate can be adjusted while the pump is running				
Audible alert	Beep sound can indicate keypad clicks, near end of run, end of run, and fault alarm				
Indicator light	Green-running, Blue-standby, Red-Warning				
Screen lock	The touch screen can be locked to prevent misoperation				
Vertical display	The display will rotate 90 degrees to support vertical operation				
Pump status when power up	Stop				
Fast forward/backward	Infuse or withdraw at full speed				
EMC	NB CE/UKCA certified				
Dimensions (LxWxH)	240mm \times 180mm \times 137mm			280mm \times 212mm \times 160mm	
Power supply for adapter	AC 90V-260V			AC 90V-260V	
Power supply for pump	DC24V/15W	DC24V/10W		DC24V/15W	
Temperature	0 - 40 $^{\circ}$ C				
Humidity	$\leq 80\%$ RH, No condensation				
Weight	2.8kg	2.9kg	2.85kg	3.65kg	3.65kg

Product Model		ASP11-1A	ASP11-1AP	ASP11-2AP	ASP12-1B	ASP12-2B
Syringe	Syringe ID (mm)	Flow rate for reference				
0.5 μ L	0.10	0.0033nL/min-0.0014mL/min	0.0009nL/min-0.0003mL/min		0.0033nL/min-0.0014mL/min	
5 μ L	0.35	0.040nL/min-0.0173mL/min	0.0108nL/min-0.0034mL/min		0.040nL/min-0.0173mL/min	
10 μ L	0.50	0.0816nL/min-0.0353mL/min	0.0221nL/min-0.0069mL/min		0.0816nL/min-0.0353mL/min	
25 μ L	0.80	0.2090nL/min-0.0904mL/min	0.0566nL/min-0.0178mL/min		0.2090nL/min-0.0904mL/min	
50 μ L	1.10	0.3951nL/min-0.1710mL/min	0.1070nL/min-0.0336mL/min		0.3951nL/min-0.1710mL/min	
100 μ L	1.60	0.8360nL/min-0.3617mL/min	0.2263nL/min-0.0711mL/min		0.8360nL/min-0.3617mL/min	
250 μ L	2.30	1.7275nL/min-0.7475mL/min	0.4676nL/min-0.1470mL/min		1.7275nL/min-0.7475mL/min	
500 μ L	3.25	3.4493nL/min-1.4925mL/min	0.9336nL/min-0.2935mL/min		3.4493nL/min-1.4925mL/min	
1mL	4.72	7.2752nL/min-3.1479mL/min	1.9692nL/min-0.6191mL/min		7.2752nL/min-3.1479mL/min	
5mL	13.10	56.041nL/min-24.248mL/min	15.169nL/min-4.7689mL/min		56.041nL/min-24.248mL/min	
10mL	16.60	89.987nL/min-38.937mL/min	24.357nL/min-7.6575mL/min		89.987nL/min-38.937mL/min	
20mL	19.00	117.89nL/min-51.009mL/min	31.909nL/min-10.032mL/min		117.89nL/min-51.009mL/min	
30mL	23.00	172.75nL/min-74.748mL/min	46.759nL/min-14.700mL/min		172.75nL/min-74.748mL/min	
60mL	29.14	277.30nL/min-119.98mL/min	75.056nL/min-23.597mL/min		277.30nL/min-119.98mL/min	
100mL	31.00	-	-		313.82nL/min-135.79mL/min	
150mL	40.00	-	-		522.50nL/min-226.08mL/min	

Laboratorial Syringe Pump

LSP04-1A



- Mainly used in biological laboratories and other places
- It is applicable to various specifications of syringes and can meet the needs of customers



Model	LSP04-1A
Specifications	
Work mode	Infusion
Channel	4
Stroke of pump	140mm
Pusher advance per microstep	0.156μm
Linear speed	5μm/min-130mm/min(Flow rate=Linear speed * Section area of the barrel)
Linear speed resolution	5μm/min
Linear travel accuracy	≤±0.5% when travel ≥30% of pump stroke
Linear force(max.)	>180N
Syringe selection	Built-in syringe branches, sizes and IDs for selection
Syringe user-defined	Can store four user-defined syringe IDs
Flow rate calibration	Improve flow rate accuracy
Running parameters setting	Infusion volume, infusion time, etc
Display setting	Display volume, flow rate or linear speed
Power-off memory	Storing the running parameters automatically
Status signal output	2 output signals (OC gate signal) to indicate start/stop and direction
Control signal input	Falling edge or TTL signal to control Start/stop
Communication interface	RS485
Dimensions (L×W×H)	280×250×140(mm)
Weight	4.5kg
Power supply	AC 90V-260V/20W
Operating temperature	0 to 40°C
Relative humidity	<80%

Controller Model (Product Code)		LSP04-1A(05.03.45A)
Syringe	Syringe ID(mm)	Flow Rate(μL/min - mL/min)
10uL	0.50	0.001μL/min-0.0255mL/min
25uL	0.80	0.0025μL/min-0.0653mL/min
50uL	1.10	0.0048μL/min-0.1235mL/min
100uL	1.60	0.0101μL/min-0.2614mL/min
250uL	2.30	0.0208μL/min-0.5401mL/min
500uL	3.25	0.0415μL/min-1.0784mL/min
1mL	4.72	0.0875μL/min-2.2747mL/min
2mL	9.00	0.3181μL/min-8.2702mL/min
5mL	13.10	0.6739μL/min-17.522mL/min
10mL	16.60	1.0821μL/min-28.135mL/min
20mL	19.00	-
30mL	23.00	-
60mL	29.14	-

Laboratorial Syringe Pump

LSP10-1B



- Mainly used in biological laboratories and other places
- It is applicable to various specifications of syringes and can meet the needs of customers



Specifications	Model	LSP10-1B
Work mode		Infusion, withdrawal, infusion/withdrawal, withdrawal/infusion, continuous
Channel		10
Stroke of pump		140mm
Pusher advance per microstep		0.156μm
Linear speed		5μm/min-130mm/min(Flow rate=Linear speed * Section area of the barrel)
Linear speed resolution		5μm/min
Linear travel accuracy		≤±0.5% when travel ≥30% of pump stroke
Linear force(max.)		>180N
Syringe selection		Built-in syringe branches, sizes and IDs for selection
Syringe user-defined		Can store four user-defined syringe IDs
Flow rate calibration		Improve flow rate accuracy
Running parameters setting		Infusion/Withdrawal volume, infusion time, withdrawal time, pause time, etc
Display setting		Display volume, flow rate or linear speed
Power-off memory		Storing the running parameters automatically
Status signal output		2 output signals (OC gate signal) to indicate start/stop and direction
Control signal input		Falling edge or TTL signal to control Start/stop
Communication interface		RS485
Dimensions (L×W×H)		280×330×140(mm)
Weight		5.3kg
Power supply		AC 90V-260V/20W
Operating temperature		0 to 40°C
Relative humidity		<80%

Controller Model (Product Code)		LSP10-1B(05.03.46A)
Syringe	Syringe ID(mm)	Flow Rate(μL/min - mL/min)
10uL	0.50	0.001μL/min-0.0255mL/min
25uL	0.80	0.0025μL/min-0.0653mL/min
50uL	1.10	0.0048μL/min-0.1235mL/min
100uL	1.60	0.0101μL/min-0.2614mL/min
250uL	2.30	0.0208μL/min-0.5401mL/min
500uL	3.25	0.0415μL/min-1.0784mL/min
1mL	4.72	0.0875μL/min-2.2747mL/min
2mL	9.00	0.3181μL/min-8.2702mL/min
5mL	13.10	0.6739μL/min-17.522mL/min
10mL	16.60	1.0821μL/min-28.135mL/min
20mL	19.00	-
30mL	23.00	-
60mL	29.14	-

Laboratorial Syringe Pump

LSP01-1C

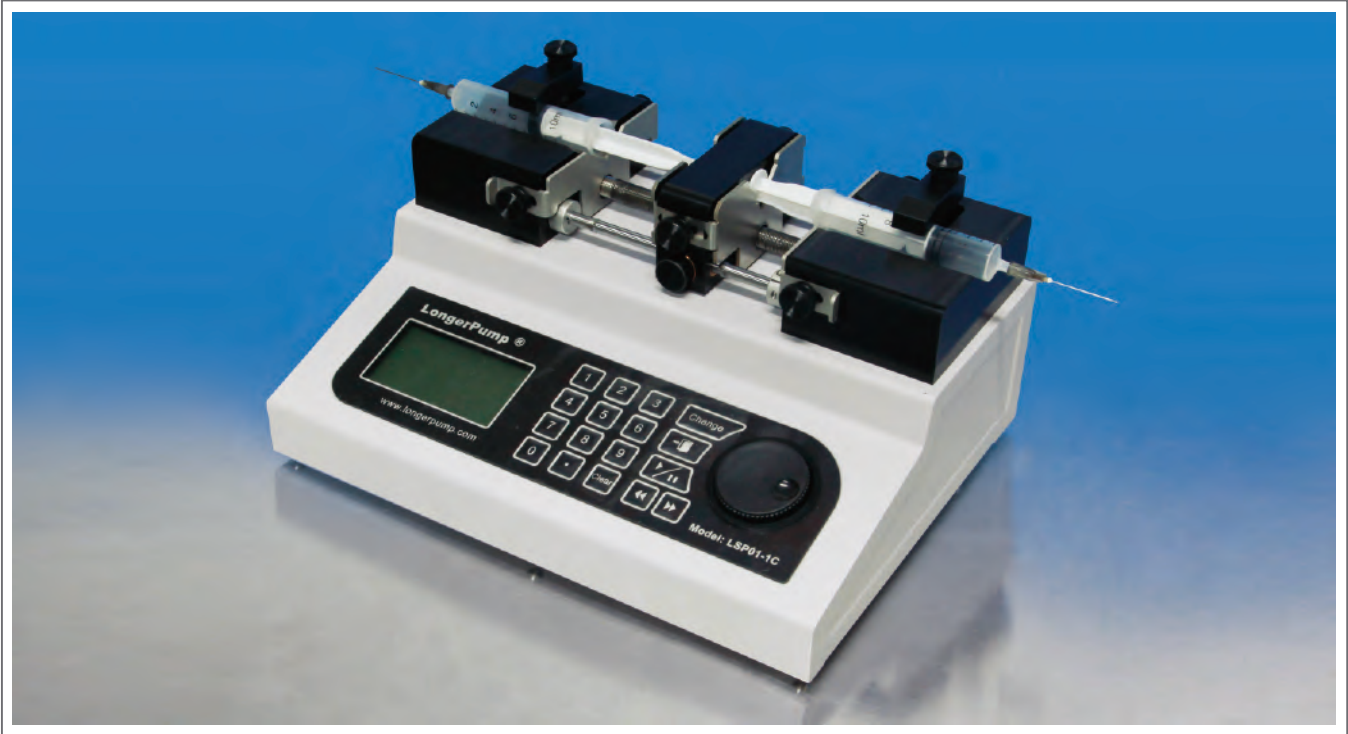

- Mainly used in laboratorial applications. High accuracy, suitable for continuous transferring of low-flow liquid.

LSP01-1C Tubing Connection Illustration

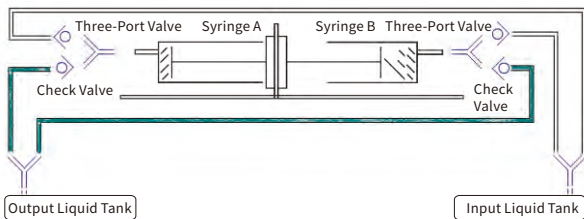

Work mode	Infusion and withdrawal synchronous and continuous
Channel	1
Stroke of pump	140mm
Pusher advance per microstep	0.156um
Linear speed	5um/min-65mm/min
Linear speed resolution	5um/min
Linear travel accuracy	≤±0.5% when travel ≥30% of pump stroke
Linear force(max.)	>90N
Syringe selection	Built-in syringe branches, sizes and IDS for selection
Syringe user-defined	Can store four user-defined syringe IDS
Flow rate calibration	Improve flow rate accuracy
Running parameters setting	Dispensing volume, infusion time, etc.
Display setting	Display volume, flow rate or linear speed
Power-off memory	Storing the running parameters automatically
Status signal output	1 OC gate signal to indicate start/stop
Control signal input	Falling edge or TTL signal to control start/stop
Communication	RS485
Dimensions (L×W×H)	280×210×140(mm)
Weight	3.6kg
Power supply	AC 90V-260V/15W
Operating temperature	0 to 40°C
Relative humidity	<80%

Model	Product Code	Syringe	Syringe ID(mm)	Flow Rate(μL/min-mL/min)
LSP01-1C	05.03.42A	10uL	0.50	0.001μL/min-0.0128mL/min
		25uL	0.80	0.0025μL/min-0.0327mL/min
		50uL	1.10	0.0048μL/min-0.0618mL/min
		100uL	1.60	0.0101μL/min-0.1307mL/min
		250uL	2.30	0.0208μL/min-0.2701mL/min
		500uL	3.25	0.0415μL/min-0.5392mL/min
		1mL	4.72	0.0875μL/min-1.1373mL/min
		2mL	9.00	0.3181μL/min-4.1351mL/min
		5mL	13.10	0.6739μL/min-8.7608mL/min
		10mL	16.60	1.0821μL/min-14.068mL/min

Laboratorial High-pressure Syringe Pump

LSP01-1BH

SYRINGE PUMP



- Mainly used in laboratorial applications.
- Suitable for viscous and high pressure liquid transferring.

Work mode	Infusion, withdrawal, infusion/withdrawal, withdrawal/infusion, continuous
Channel	1
Stroke of pump	140mm
Pusher advance per microstep	0.156 μ m
Linear speed	5 μ m/min-130mm/min
Linear speed resolution	5 μ m/min
Linear travel accuracy	$\leq \pm 0.5\%$ when travel $\geq 30\%$ of pump stroke
Linear force(max.)	$> 450\text{N}$
Syringe selection	Built-in syringe branches, sizes and IDs for selection
Syringe user-defined	Can store four user-defined syringe IDs
Flow rate calibration	Improve flow rate accuracy
Running parameters setting	Infusion volume, infusion time, withdrawal time, pause time, etc
Display setting	Display volume, flow rate or linear speed
Power-off memory	Storing the running parameters automatically
Status signal output	2 output signals (OC gate signal) to indicate start/stop and direction
Control signal input	Falling edge or TTL signal to control Start/stop
Communication interface	RS485
Dimensions (L×W×H)	280×250×140 (mm)
Weight	6.3kg
Power supply	AC 90V-260V/25W
Operating temperature	0 to 40°C
Relative humidity	$< 80\%$

Model	Product Code	Syringe(mL)	Syringe ID(mm)	Flow Rate (μ L/min-mL/min)	Outlet Pressure (Mpa)
LSP01-1BH	05.03.43A	2.5	4.79	0.0901 μ L/min-2.3426mL/min	19.48
		8	9	0.3181 μ L/min-8.2702mL/min	7.07
		20	19.05	1.4251 μ L/min-37.053mL/min	1.58
		50	28.6	3.2121 μ L/min-83.5152mL/min	0.56
		100	34.9	4.7831 μ L/min-124.361mL/min	0.37

Micro Gear Pump

WT3000 Series



- Mainly used in laboratorial applications.
- Brushless motor, stainless steel pump head.



GEAR PUMP

Pump Specification

Specifications	Model	WT3000-1FA	WT3000-1FB-A, WT3000-1FB-B	WT3000-1JA	WT3000-1JB-A, WT3000-1JB-B
Speed		300rpm-3000rpm			
Speed resolution		1rpm			
Dispensing volume		0.1mL-999L		Not available	
Copy number		0-9999, "0" means unlimited cycle			
Pause time		1s-999hr, resolution is 0.1s			
Calibration time		30s-1800s, resolution is 1s			
Diameter of particle in liquid		≤10μm			
Viscosity		≤200cSt			
Speed signal input		4-20mA, 0.5-5V, 1-10V, 1-10kHz corresponding to 300rpm-3000rpm			
Start/Stop signal input		TTL signal			
Speed output		1.25kHz-12.5kHz corresponding to 300rpm-3000rpm		Not available	
Start/Stop output		OC gate signal			
Communication interface		RS485			
Dimension (L×W×H)		232×142×149(mm)	290×207×180(mm)	232×142×149(mm)	290×207×180(mm)
Power supply		AC 90V-260V/50W	AC 220V±20%/150W or AC 110V±20%/150W	AC 90V-260V/50W	AC 220V±20%/150W or AC 110V±20%/150W
Operating condition		0 to 40°C			
Relative humidity		<80%			
IP rating		IP31			
Weight		2.83kg	5.1kg	2.83kg	5.1kg

Drive Model (Product code, Power supply)	Pump Head	Gear Material	Flow Rate (mL/min)	Outlet Pressure (Mpa)	Liquid Temperature (°C)	Weight (kg)
WT3000-1JA(05.06.01A)	MG204XD0PT00000	PEEK	85.7-857.1	≤0.8	-45-120	3.25
	MG204XD0TT00000	PTFE	85.7-857.1	≤0.8	-45-50	3.25
	MG209XD0PT00000	PEEK	171.4-1714.3	≤0.8	-45-120	3.26
WT3000-1FA(05.06.03A)	MG209XD0TT00000	PTFE	171.4-1714.3	≤0.8	-45-50	3.26
	MG213XD0PT00000	PEEK	257.1-2571.4	≤0.3	-45-120	3.28
	MG213XD0TT00000	PTFE	257.1-2571.4	≤0.3	-45-50	3.28
WT3000-1JB-A(05.06.02A, AC220V)	MS204XD0PT00000	PEEK	85.7-857.1	≤1.4	-45-120	5.39
WT3000-1JB-B(05.06.02B, AC110V)	MS209XD0PT00000	PEEK	171.4-1714.3	≤0.9	-45-120	5.4
WT3000-1FB-A(05.06.04A, AC220V)						
WT3000-1FB-B(05.06.04B, AC110V)	MS213XD0PT00000	PEEK	257.1-2571.4	≤0.8	-45-120	5.42

■ Customizable OEM Product Series

Hemodialysis Pump

MTH18-12



- Mainly used in hemodialysis applications.
- DC brushless motor, more stable, low noise.
- Small size, compact structure, ideal for OEM equipment and instruments.
- Brushless motor drive board (model:BLDCDRV-B1) is available. Or work with customer's specific drive board.

The lever of the rotor assembly helps to load the tubing easily and run the pump head manually.

The tubing and pump running condition can be easily monitored through the transparent PC cover. Cover open to stop to protect the operator and monitor pump status.

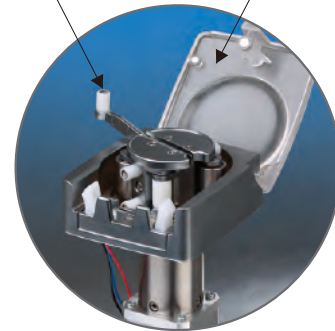

HEMODIALYSIS PUMP

Installation Drawing

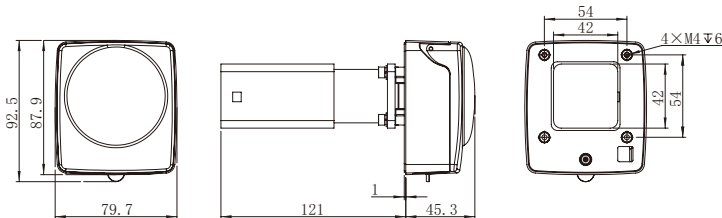

Motor Specification

Voltage rating	24VDC
Current rating	3.2A
Pole-pairs number	4
Speed rating	4000rpm
Reduction ratio	1:19

Motor Wiring

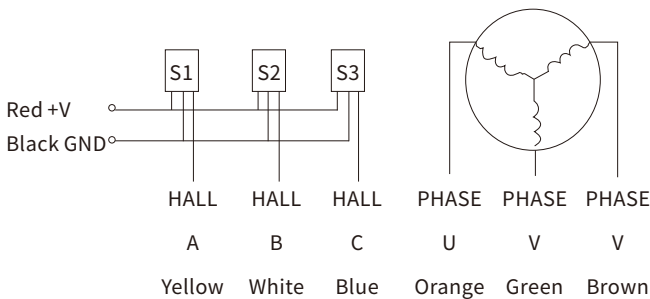

Pump Specification

Speed	0-70rpm, CW/CCW
Tubing	OD≤10mm, Wall thickness 1.75±0.2mm
Flow rate	5-300mL/min(6.5mmID×10mmOD) 2-165mL/min(4.6mmID×8.4mmOD)
Dimension(L×W×H)	166×80×93mm
Relative humidity	<80%
Operating temperature	0 to 40°C
Weight	1.23kg

Model	Product Code	Roller Number	Roller Material	Housing and Cover Material	Speed (rpm)	Tubing ID×OD(mm)	Flow Rate (Only for reference)
MTH18-12	05.21.01A	2	304SS	Housing; Zinc Alloy /Chrome Coating Cover: PC	≤70rpm	6.5×10	5-300
						4.6×8.4	2-165

dPOFLEX[®] High Precision Filling System

PFU, PFS

- Precise filling of micro-volume as low as 30uL, accuracy better than $\pm 1\%$
- Can be used independently as a small benchtop filling system, or integrated into semi-automatic systems or fully automated systems
- The master controller can control up to 32 channels, which can be set with individual parameters
- Three levels of user accesses, operation log, batch report with electronic signature, for FDA 21CFR Part 11 compliance



DISPENSING&FILLING SYSTEM

	PFU (Single Channel)	PFS (Four Channels)
Pump head	PFH01(microliter pump head) , PFH02 (milliliter pump head)	
Tubing	Silicone tubing and tubing kits	
Filling volume	1uL- 99.99L	
Filling accuracy	better than $\pm 1\%$	
Filling precision	CV< 0.5%	
Filling time	0.1seconds-999.9hours	
Filling cycle	0-999999 (0 means unlimited)	
Interval time	0.1s - 999.9s	
Back suction parameter	0-30	
Working direction	Clockwise	
Calibration	Manual input calibration, balance reading calibration or online ratio calibration, with volume or mass data	
Display	7 inch touch screen, Chinese or English can be set	
Work mode	Single channel filling, multi-channel filling with the same parameters or individual parameters	
Access management and password protection	Three levels of user accesses (administrator, developer, operator), each user can have an exclusive password	
Parameter recipe	Up to 500 recipes can be stored and recalled easily on the PFC controller	
Batch report	Up to 800 batch reports can be stored on the PFC controller, which can be saved to USB flash drive or printed directly	
Communication control	Rs485 interface, Modbus RTU protocol	Rs485 interface, Modbus RTU protocol; or Ethernet interface, TCP/IP protocol as optional
External control input	Start the pump, emergency stop, disable channel	
Output	1 output for malfunction status	
IP rating	IP31	IP32
Power supply	AC 100V-240V , 50/60Hz , 60W	AC 100V-240V , 50/60Hz , 250W
Dimension (L*W*H)	119mm×203mm×176mm (without pump head)	548mm×245mm×198mm (without pump head)
Weight of system	3.5kg (without pump head)	16.1kg (without pump head)
Dimension of controller (L*W*H)	187mm×123mm×39mm	
Weight of controller	0.6kg	
Working condition	Temperature: 5 - 40°C , RH: $\leq 85\%$, no condensation	
Storage and transportation condition	Temperature: -40 - 70°C, RH: $\leq 85\%$, no condensation	

Dispensing & Filling System - Peristaltic Pump

FU4B-1&FC32S-1, FU5B-1&FC32S-1



- Mainly designed for automatic filling & dispensing machine.
- 304ss housing has good corrosion resistance.
- Controller FC32S-1 and dispensing system FU4B-1/FU5B-1 are separated, to allow flexible mounting way.
- One dispensing unit of FU4B-1 has four channels, one dispensing unit of FU5B-1 has five channels. With modular structure, one controller can control 32 channels.
- Controller adopts 7 inch industrial touchscreen interface to operate easily and friendly.
- Each channel has independent membrane key and LED display, which can be used to set the channel address and calibrate the dispensing volume when system is running or stop.



DISPENSING&FILLING SYSTEM

Dispensing volume	0.1ml-9999.99ml (resolution: 0.01ml)
Dispensing time	0.5s-6000s (resolution: 0.1s)
Interval time	0.5s-999.9s
Dispensing cycle	0-999999, "0" means unlimited cycle
Delay time before back suction	0-60.0s
Back suction angle	0-1000°
Channel quantity	One FU4B-1 has 4 channels, one FU5B-1 has 5 channels. The system channels can be expended by modular structure. One controller can control 32 channels
Display	LCD
Control mode	Touchscreen control, external signal control or communication control
Start control signal input	Each dispensing unit has one pair of terminals for the external start signal
No bottle signal input	Each channel has individual terminals for the no bottle signal
Communication function	Rs485 communication interface, Modbus protocol, communication parameters (address, baud rate, parity, stop bit) can be set through touchscreen
Dispensing calibration	Dispensing volume of every channel can be calibrated through percentage, volume, weight or average weight method.
Channel enable	Every channel can be set as enable or disable
Fill/Backflow	All channels can be fast filling or backflowing at high speed simultaneously or separately
Channel address	Communication address of each channel can be set through independent membrane key and displayed on independent LED
Password function	Protect the system parameters and prevent misoperation through the password function
Dispensing parameter set	Dispensing parameters can be saved as a parameter set which can be invoked easily without reset it.
Dispensing unit dimension(L×W×H)	FU4B-1 (4 channels): 663mm × 218mm × 177mm FU5B-1 (5 channels): 823mm × 218mm × 177mm
Controller dimension(L×W×H)	228mm × 60mm × 146mm
Power supply	FU4B-1/FU5B-1 : AC220V±20%/300W, FC32S-1: AC90V-260V/10W
Operating temperature	0 to 40°C
Relative humidity	<80%
IP rating	IP31
Weight	FU4B-1: 12kg, FU5B-1: 15kg, controller: 1.7kg

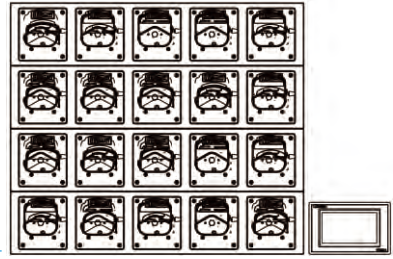

Model (Product Code)	Pump Head	Ref. Dispensing Volume (mL)	Tubing	Ref. Dispensing time (s)	Accuracy	Ref. Dispensing ID (mm)	Productivity (pcs/min)	
Dispensing System	YZ1515x YZ1115 FG15-13	0.3-0.5	13 [#]	1-1.2	≤ ±2%	≤0.5	27-30	
		1.0-2.3	14 [#]			≤1.0		
		2.6-5.1	19 [#]			≤1.5		
		4.6-9.1	16 [#]			≤2.0		
		10-19	25 [#]			≤3.0		
	FU4B-1 (05.11.02A) FU5B-1 (05.11.03A)	YZ1125	15-30			17 [#]		≤3.0
			8.0-17			15 [#]		≤3.0
			12-24			24 [#]		≤3.0
			8.5-17			15 [#]		≤3.0
			15-24			24 [#]		≤3.0
Controller	FG25-13	18-36	35 [#]	≤3.0				
		25-48	36 [#]	≤3.0				
		9-17	15 [#]	≤3.0				
		12-24	24 [#]	≤3.0				
FC32S-1 (05.49.27A)	DMD15-13-B DMD15-13-D	0.1-0.9	2 × 13 [#]	≤0.5				
		0.2-2.3	2 × 14 [#]	≤1.0				
		0.5-5.9	2 × 19 [#]	≤2.0				
		2.0-10	2 × 16 [#]	≤3.0				
		5.0-25	2 × 25 [#]	≤3.0				

Industrial Syringe Pump

SP1-CX, MSP1-CX



SP1-CX



MSP1-CX

- Mainly used in OEM equipment and instruments, especially for laboratory automation systems and IVD applications.
- Rotating valve, and misc. accessories available.
- RS485, RS232 or CAN bus communication interface.



	SP1-CX	MSP1-CX
Main Spec		
Accuracy	≤1.0% (syringe ≥1 mL)	
Precision	CV≤0.05% at full stroke (with syringe ≥ 500uL)	CV≤0.05% at full stroke (with syringe ≥1mL)
Wetted material	Borosilicate glass, PTFE, PFA, CTFE, ETFE, UHMW-PE, Ceramic	
Dimension(L×W×H)	114mm x 65mm x 254mm	110mm x 44.4mm x127mm
Weight	2.15 kg	1.0 kg
Power supply	DC 24V, 1.5A (peak)	
Syringe and Drive		
Syringe fitting	1/4"-28 thread	
Syringe	50uL, 100uL, 250uL, 500uL, 1mL, 2.5mL, 5mL, 10mL, 25mL	50uL, 100uL, 250uL, 500uL, 1mL, 2.5mL, 5mL
Syringe material	Borosilicate glass, stainless steel plunger with PTFE coating, PTFE or UHMW-PE plunger tip	
Resolution (standard mode)	6000 steps with 0.01mm in 1 step	3000 steps with 0.01mm in 1 step
Resolution (microstep mode)	48000 microsteps with 1.25um in 1 microstep	48000 microsteps with 0.625um in 1 microstep
Travel	60mm	30mm
Time for full stroke	1.26s-1200s	
Drive system	Ball screw drive with optical encoder	
Valve & Valve Drive		
Turn Time	≤250ms between adjacent ports	
Valve options	3-port Y valve, 3-port distribution valve, 4-port valve, 6-port distribution valve, 9-port distribution valve, T valve, straight-through valve or distribution valve.	
Max pressure	0.68MPA	
Fitting	1/4"-28 thread	
Communication		
Interface	RS485, RS232, CAN bus, external control input and output	
Protocol	Data terminal, OEM protocol (serial) or CAN	
Baud rate	RS485 or RS232: 9600bps or 38400bps CAN bus: 100 KB, 125 KB 250 KB, 500 KB or 1MB	
Format	Data bit: 8; parity: none; stop bit: 1; half duplex (RS232/485)	
Firmware		
Topology group	Up to 15 pumps in one group, support group control and individually addressed	
Upgrade firmware online	"One Click" by customer through PC Utility	
Homing Algorithm	Plunger home position is identified by motor stall, which will reduce the dead volume of the system	
Halt function	For better interactive control, "h" command is used to halt execution of the command string during plunger movement. To resume execution with "R" or "r" command	
Microstep mode	Set microstep mode for smoother motion with 48000 microsteps per stroke, 1/8 microstepping or 1/16 microstepping	
Programmable parameter	Programmable ramps, cut-off velocity, plunger speeds, backlash compensation, programmable work-flow command set, delays and loops, terminate moves, diagnostics, absolute and relative positions	
Environmental		
Operating temperature	Recommended: 15°C-40°C, use low temperature syringe for low temperature application	
Operating Humidity	<80% RH, no condensation	
Storage temperature	-20°C-65°C	
Storage Humidity	<80% RH, no condensation	

Industrial Syringe Pump

MSP1-D1, MSP1-E1



- Mainly used in OEM equipment and instruments, especially in automation systems.
- Rotating valve, panel installation, RS485 or RS232 communication control.

Specifications	Model	MSP1-D1	MSP1-E1
Accuracy		≤1%(rated stroke)	
Precision		Repeatability≤0.5%(rated stroke)	
Rated stroke (steps)		30mm(1000 steps)	
Linear speed		0.5mm/s-15mm/s	
Time for rated stroke		2s-60s	
Control resolution		0.03mm(1 step)	
Transmission mechanism		Rack and pinion drive	
Plunger drive force (max.)		≥68N	
Secondary plunger drive force (max.)		≥34N	-
Syringe		500μL, 1mL, 2.5mL, 5mL	
Valve		3 port 120°	3-way solenoid valve
Valve plug turn time		≤280ms between adjacent ports	≤100ms
Wetted material		Borosilicate glass, PTFE, PCTFE	Borosilicate glass, PTFE, PEEK
Max. pressure		0.68Mpa	0.1Mpa
Tubing fitting		1/4"-28 thread	
Syringe fitting		1/4"-28 thread	
Signal input		1 input signals (TTL signal, drive current > 16mA)	
Signal output		1 output signals (OC gate signal) to indicate the working status	
Communication interface		RS485 or RS232	
Bit rate		9600bps or 38400bps	
Pump ID setting		Set the pump ID through BCD dial switch (0 to E corresponding to pump address 1-15)	
Pump parameters setting		Set the parameters through DIP switch	
Dimension (L×W×H)		100×65×127(mm)	
Power supply		DC 24V/1.5A	
Operating temperature		15 to 40°C	
Relative humidity		<80%	
Weight		0.9kg	

Industrial Multi-Channel Syringe Pump

SP4-D1, SP4-E1



- Mainly used in OEM equipment and instruments, especially in automation systems.
- Four synchronously running channels, high strength housing, panel or soleplate installation, RS485 or RS232 communication control.

Specifications	Model	SP4-D1	SP4-E1
Accuracy		≤1% (rated stroke)	
Precision		Repeatability≤0.5% (rated stroke)	
Rated stroke (steps)		60mm (1000 steps)	
Linear speed		0.03mm/s-24mm/s	
Time for rated stroke		2.5s-2000s	
Control resolution		0.06mm (1 step)	
Transmission mechanism		Synchronous belt mechanism	
Plunger drive force (max.)		≥68N for four channels	
Syringe		50μL, 100μL, 250μL, 500μL, 1mL, 2.5mL, 5mL	
Valve		No	3-way solenoid valve
Valve plug turn time		-	≤100ms
Wetted material		Borosilicate glass, PTFE, PPS	Borosilicate glass, PTFE, PEEK
Max. pressure		0.68 MPa (valve)	0.1MPa
Tubing fitting		1/4"-28 thread	
Syringe fitting		1/4"-28 thread	
Signal input		2 input signals (TTL signal, drive current >16mA) to restart the pump after pause	
Signal output		3 output signals (OC gate signal) to indicate the working status	
External Solenoid valve control		Can control 4 pcs of independent 24VDC solenoid valve. The rated drive signal for each valve is DC24V/200mA	With built-in solenoid valve
Communication interface		RS485 or RS232	
Bit rate		9600bps or 38400bps	
Pump ID setting		Set the pump ID through BCD dial switch	
Pump parameters setting		Set the parameters through DIP switch	
Dimension (L×W×H)		140×167×261.5 (mm)	
Power supply		DC 24V/1.5A	
Operating temperature		15 to 40°C	
Relative humidity		<80%	
Weight		2.4kg	

OEM Peristaltic Pump Head

KZ10-24, KZ15-14

Max. Flow Rate



- Compact structure, suitable for OEM peristaltic pump.
- Two to four heads can be stacked for multi-channel applications.

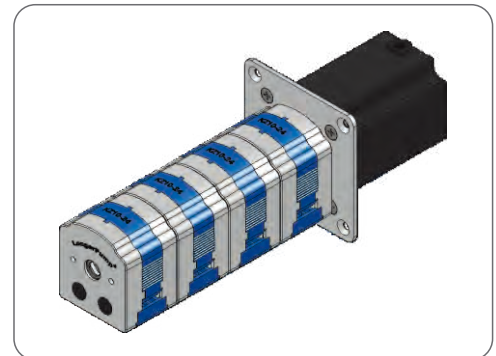

OEM PERISTALTIC PUMP

Installation Drawing

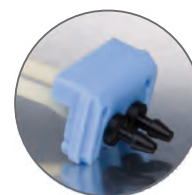
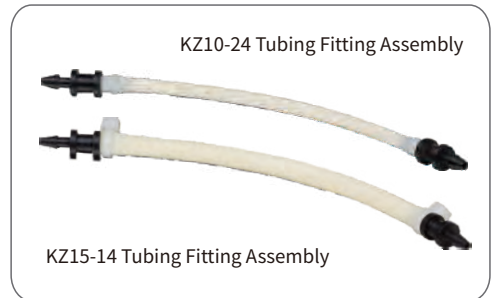
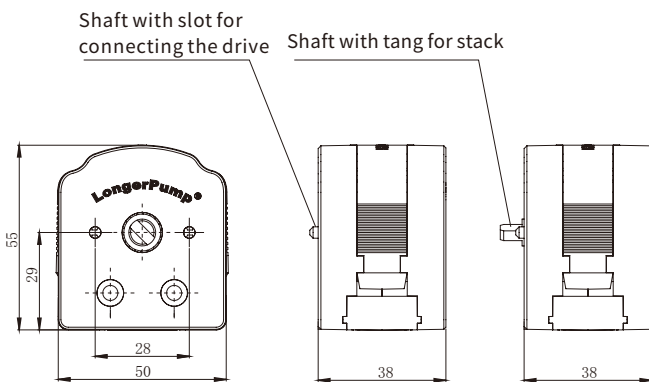

KZ10-24 tubing clammer

KZ15-14 tubing clammer

Model	Shaft	Product Code	Channel Number	Roller Number	Roller Material	Housing Material	Speed (rpm)	Tubing	Max. Flow Rate (mL/min)	Weight (kg)		
KZ10-24-A	Slot	05.01.27A	2	4	POM	POM	≤450	ID≤2.79(mm) Wall thickness 0.86(mm)	104	0.1		
KZ10-24-B	Tang	05.01.27B			PVDF	PVDF						
KZ10-24-C	Slot	05.01.27C			POM	POM						
KZ10-24-D	Tang	05.01.27D			PVDF	PVDF						
KZ15-14-A	Slot	05.01.28A	1		4	POM		POM	13" 14" 19" 16"		190	0.1
KZ15-14-B	Tang	05.01.28B				PVDF		PVDF				
KZ15-14-C	Slot	05.01.28C				POM		POM				
KZ15-14-D	Tang	05.01.28D				PVDF		PVDF				

OEM Peristaltic Pump Without Control Board

T-S403

Max. Flow Rate



- Step Motor. Special pump head mounting bracket can be fitted with single KZ15-14 or KZ10-24 pump head.
- Ideal OEM peristaltic pump for equipments and instruments.
- Panel installation as standard. Soleplate installation can be customized.
- Meet RoHS requirement.

Installation Drawing

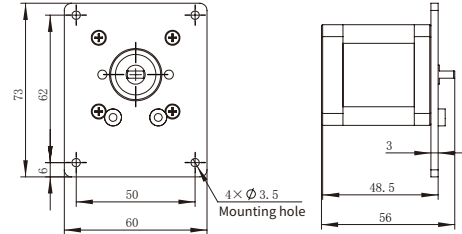

Pump Specification

Speed	≤100rpm
Dimension(L×W×H)	56×60×73(mm)
Relative humidity	<80%
Operating temperature	0 to 40°C

Motor Specifications

Step angle	1.8°
Phase	2
Phase voltage	6.56V
Phase current	0.8A
Resistance	8.2Ω±10%
Inductance	15.4mH±20%

Motor Port

Line Color	Definition
Brown	A
Orange	A̅
Red	B
Yellow	B̅

Model (Product Code)	Pump Head (Product Code)	Channel Number	Roller Number	Roller/Housing Material	Speed (rpm)	Tubing	Max. Flow Rate (mL/min)
T-S403 (05.65.203)	KZ10-24-A (05.01.27A)	2	4	POM	≤100rpm	ID≤3.17mm Wall thickness 0.86mm	23
	KZ10-24-C (05.01.27C)						
	KZ15-14-A (05.01.28A)	1		POM		13" 14" 19" 16"	42
	KZ15-14-C (05.01.28C)			PVDF			

T-S400

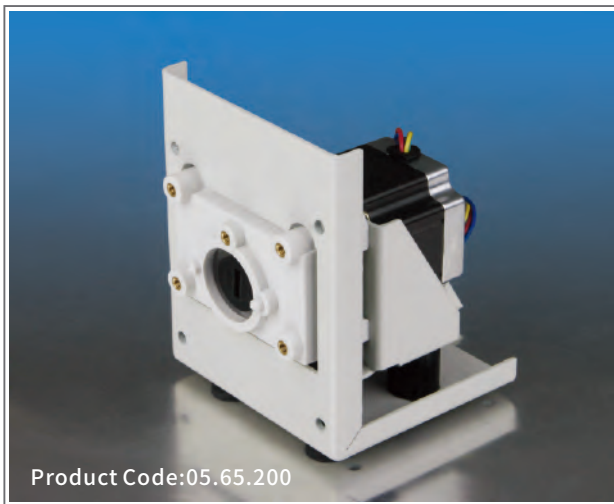

Max. Flow Rate



- Use step motor. Standard pump head mounting bracket can be fitted with several different pump heads.
- Ideal OEM peristaltic pump for equipment and instruments.
- Soleplate or panel installation.
- Meet RoHS requirement.

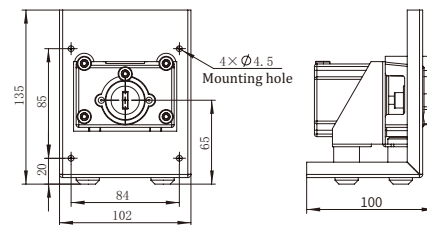

Pump Specification

Speed with DG pump head	≤100rpm
Speed with other pump head	≤300rpm
Dimension (L×W×H)	100×102×135 (mm)
Relative Humidity	<80%
Operating Temperature	0 to 40°C

Motor Specifications

Step angle	1.8°
Phase	2
Phase voltage	2.7V
Phase current	1.5A
Resistance	1.8Ω±10%
Inductance	4.5mH±20%

Motor Port

Line Color	Definition
Red	A
Green	A̅
Yellow	B
Blue	B̅

Pump Head	Tubing	Max. Flow Rate (mL/min)
YZ1515x, YZ1115	13" 14" 19" 16" 25" 17" 18"	1140
YZ2515x, YZ1125	15" 24"	840
DG-1(6), DG-2(6)	ID ≤3.17(mm)	48(Single Channel)
DG-1(10), DG-2(10)	Wall Thickness 0.8-1(mm)	32(Single Channel)
BZ15-13-A	14"	75
BZ15-13-B	16"	230
BZ15-13-C	25"	480
BZ15-13-D	17"	840
BZ25	24"	800
FG15-13-B	13" 14" 19" 16" 25" 17" 18"	1300
FG25-13-B	15" 24"	900
DMD15-13-B	2×13" 2×14"	1050
DMD15-13-D	2×19" 2×16" 2×25"	

OEM Peristaltic Pump Without Control Board

T-S500&WX10-14-H

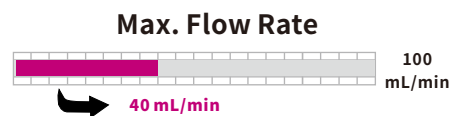

- Use WX10-14-H pump head and step motor.
- Ideal OEM peristaltic pump for equipment and instruments.
- Soleplate installation is standard, panel installation is optional.
- Meet RoHS requirement.

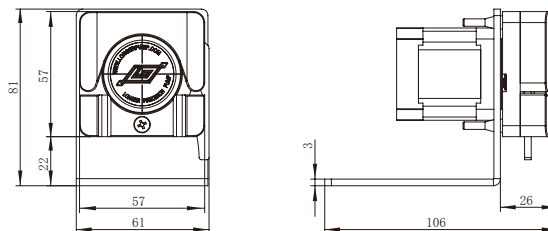

Pump Specification

Speed	≤100rpm
Max. Flow Rate	40mL/min
Tubing	ID≤3.17mm, wall thickness 0.8mm-1.0mm
Dimension (L×W×H)	106×61×81 (mm)
Relative humidity	<80%
Operating temperature	0 to 40°C

Motor Specifications

Step angle	1.8°
Phase	2
Phase voltage	6.56V
Phase current	0.8A
Resistance	8.2Ω±10%
Inductance	13.9mH±20%

Motor Port

Line Color	Definition
Brown	A
Orange	\bar{A}
Red	B
Yellow	\bar{B}

T-S501&JY15-12-C

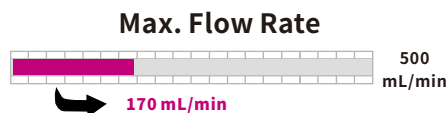

- Use JY15-12-C pump head and step motor.
- Ideal OEM peristaltic pump for equipment and instruments.
- Soleplate installation is standard, panel installation is optional.
- Meet RoHS requirement.

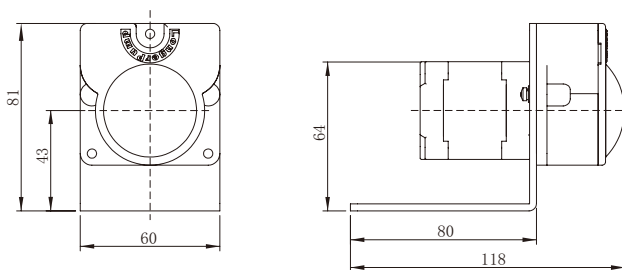

Pump Specification

Speed	≤100rpm
Dimension(L×W×H)	118×60×81(mm)
Relative humidity	<80%
Operating temperature	0 to 40°C

Tubing	Max. Flow Rate(mL/min)
25"	118mL/min
17"	170mL/min

Motor Specifications

Step angle	1.8°
Phase	2
Phase voltage	6.56V
Phase current	0.8A
Resistance	8.2Ω±10%
Inductance	13.9mH±20%

Motor Port

Line Color	Definition
Brown	A
Orange	\bar{A}
Red	B
Yellow	\bar{B}

OEM PERISTALTIC PUMP

OEM Variable Speed Peristaltic Pump

Max. Flow Rate



T100&WX10-14 Series

OEM PERISTALTIC PUMP



- Use WX10-14 pump head.
- Mainly designed for OEM applications.
- Multi-control modes are available.
- Soleplate installation is standard, panel installation is optional.

Installation Drawing

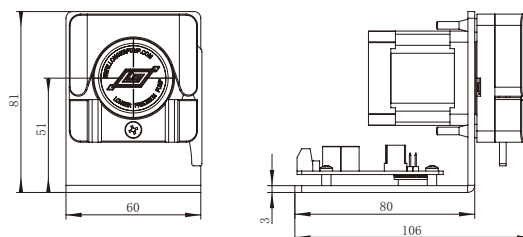

Pump Specification

Items	Specification
Speed	≤100rpm
Speed resolution	0.1rpm
Max. flow rate	40mL/min
Tubing	ID≤3.17mm wall thickness 0.8mm-1.0mm
*Direction control	Direction is controlled by external switch signal.CW when switch is open, CCW when switch is closed
*Start/stop control	Start/stop is controlled by external switch signal. Pump runs when switch is open, stops when switch is closed
*BCD dial switch speed control	The speed is divided into 15 grades. BCD position 1-F corresponding to (rpm)5,10,15,20,25,30,35,40,45,50,60, 70,80,90,100 (rpm)
*External speed control (optional)	4-20mA corresponding to 0.1-100rpm, 0-5V corresponding to 0-100rpm, 0-10V corresponding to 0-100rpm, 0-10kHz corresponding to 0-100rpm
**Communication pump ID	Pump ID range is 1-30
**Bit rat	1200bps or 9600bps
Dimension (L×W×H)	106 x 60 x 81 (mm)
Relative humidity	<80%
Operating temperature	0 to 40°C
Power supply	DC11.4V-25.2V
Power consumption	≤12W
Weight	0.51kg

Note: Items with * are only available for products with dial switch and external speed control signal.
Items with ** are only available for product with RS485.



Pump Selection Table

Model	Product Code	Control Mode	Certificate
T100-S300&WX10-14-H	056001H	Dial switch and external signal (4-20mA)	CE certified and Meet RoHS requirement
T100-S301&WX10-14-H	056002H	Dial switch and external signal (0-5V)	
T100-S302&WX10-14-H	056003H	Dial switch and external signal (0-10V)	
T100-S303&WX10-14-H	056004H	Dial switch and external signal (0-10kHz)	
T100-S500&WX10-14-H	056005H	RS485 communication	

OEM Variable Speed Peristaltic Pump

Max. Flow Rate



T100&JY15-12 Series



- Use JY15-12 pump head, Mainly designed for OEM applications.
- Multi-control modes are available.
- Soleplate installation is standard, panel installation is optional.

Installation Drawing

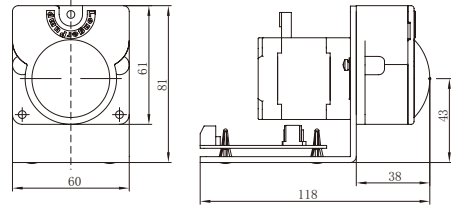

Tubing	Max. Flow Rate(mL/min)
25"	118mL/min
17"	170mL/min

OEM PERISTALTIC PUMP

Pump Specification

Items	Specification
Speed	≤100rpm
Speed resolution	0.1rpm
*Direction control	Direction is controlled by external switch signal.CW when switch is open, CCW when switch is closed
*Start/stop control	Start/stop is controlled by external switch signal. Pump runs when switch is open, stops when switch is closed
*BCD dial switch speed control	The speed is divided into 15 grades. BCD position 1-F corresponding to (rpm)5,10,15,20,25,30,35,40,45,50, 60,70,80,90,100 (rpm)
*External speed control (optional)	4-20mA corresponding to 0.1-100rpm, 0-5V corresponding to 0-100rpm, 0-10V corresponding to 0-100rpm, 0-10kHz corresponding to 0-100rpm
**Communication pump ID	Pump ID range is 1-30
**Bit rate	1200bps or 9600bps
Dimension (L×W×H)	118×60×81(mm)
Relative humidity	<80%
Operating temperature	0 to 40°C
Power supply	DC11.4V-25.2V
Power consumption	≤12W
Weight	0.54kg

Note: Items with * are only available for products with dial switch and external speed control signal.
Items with ** are only available for product with RS485.

Pump Selection Table

Model	Product Code	Control Mode	Certificate
T100-S300&JY15-12-C	056030C	Dial switch and external signal (4-20mA)	CE certified and Meet RoHS requirement
T100-S301&JY15-12-C	056031C	Dial switch and external signal (0-5V)	
T100-S302&JY15-12-C	056032C	Dial switch and external signal (0-10V)	
T100-S303&JY15-12-C	056033C	Dial switch and external signal (0-10kHz)	
T100-S500&JY15-12-C	056034C	RS485 communication	

OEM Variable Speed Peristaltic Pump

T100-S320

Max. Flow Rate



OEM PERISTALTIC PUMP



- Multi-control Modes.
- Special pump head mounting bracket can be fitted with single KZ15-14 or KZ10-24 pump head.
- Ideal OEM peristaltic pump for equipment and instruments.
- Soleplate or panel installation.

Installation Drawing

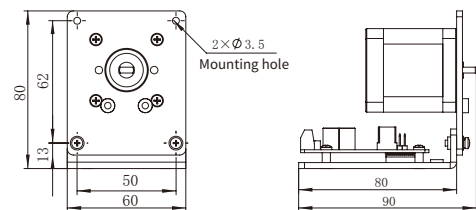

Pump Specification

Items	Specification
Speed	≤100rpm
Speed resolution	0.1rpm
*Direction control	Direction is controlled by external switch signal. CW when switch is open, CCW when switch is closed
*Start/stop control	Start/stop is controlled by external switch signal. Pump runs when switch is open, stops when switch is closed
*BCD dial switch speed control	The speed is divided into 15 grades. BCD position 1-F corresponding to 5, 10, 15, 20, 25, 30, 35, 40, 45, 50, 60, 70, 80, 90, 100 (rpm)
*External speed control(optional)	4-20mA corresponding to 0.1-100rpm, 0-5V corresponding to 0-100rpm, 0-10V corresponding to 0-100rpm, 0-10kHz corresponding to 0-100rpm
**Communication pump ID	Pump ID range is 1-30.
**Bit rate	1200bps or 9600 bps
Dimension(L×W×H)	90×60×80(mm)
Relative humidity	<80%
Operating temperature	0 to 40°C
Power supply	DC11.4V-25.2V/12W

Note: Items with * are only available for products with dial switch and external speed control signal.

Pump Selection Table

Model	Product Code	Control Mode	Certificate
T100-S320	05.60.130	Dial switch and external signal (4-20mA)	Meet RoHS requirement
T100-S321	05.60.131	Dial switch and external signal (0-5V)	
T100-S322	05.60.132	Dial switch and external signal (0-10V)	
T100-S323	05.60.133	Dial switch and external signal (0-10kHz)	
T100-S502	05.60.202	RS485 communication	

Model (Product Code)	Pump Head (Product Code)	Channel Number	Roller Number	Roller/Housing Material	Speed (rpm)	Tubing	Max. Flow Rate (mL/min)
KZ10-24-A	05.01.27A	2	4	POM	≤100rpm	ID≤3.17mm Wall thickness 0.86mm	23
KZ10-24-C	05.01.27C			PVDF			
KZ15-14-A	05.01.28A	1		POM		13" 14" 19" 16"	42
KZ15-14-C	05.01.28C			PVDF			

OEM Variable Speed Peristaltic Pump

Max. Flow Rate



T100/T300/T600 Series

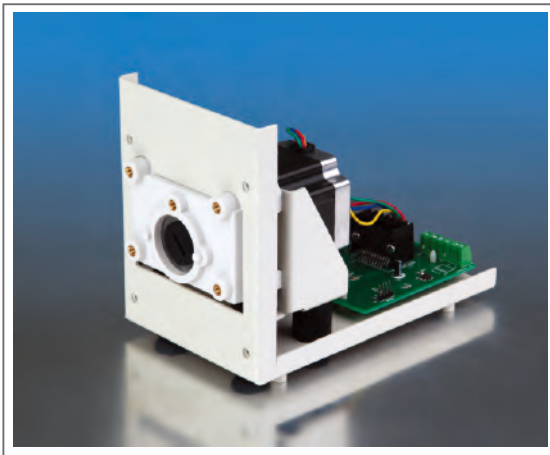

- Good EMC performance.
- Multi-control modes.
- Standard pump head mounting bracket can be fitted with several different pump head.
- Low vibration, low noise.
- Soleplate or panel installation.



Installation Drawing

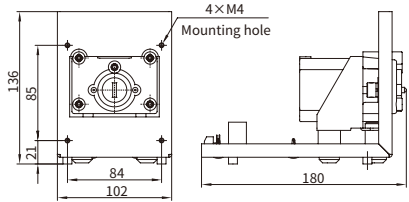

T100 Series

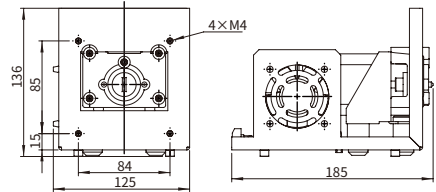

T300/T600 Series

Pump Specification

Item	T100 Series	T300 Series	T600 Series
Speed	0-100rpm	0-300rpm	0-600rpm
Speed resolution	0.1rpm	1rpm	1rpm
*Direction control	Direction is controlled by external switch signal. CW when switch is open, CCW when switch is closed		
*Start/stop control	Start/stop is controlled by external switch signal. Pump runs when switch is open, stops when switch is closed		
*BCD dial switch speed control	The speed is divided into 15 grades. BCD position 1-F corresponding to 5, 10, 15, 20, 25, 30, 35, 40, 45, 50, 60, 70, 80, 90, 100(rpm)	The speed is divided into 15 grades. BCD position 1-F corresponding to 5, 10, 20, 40, 60, 80, 100, 125, 150, 175, 200, 225, 250, 275, 300(rpm)	The speed is divided into 30 grades: 5, 10, 20, 40, 60, 80, 100, 125, 150, 175, 200, 225, 250, 275, 300, 320, 340, 360, 380, 400, 420, 440, 460, 480, 500, 520, 540, 560, 580, 600 (rpm)
*External speed control signal (optional)	4-20mA, 0-5V, 0-10V, 0-10kHz		
**Communication control	RS485 interface, compatible both with Longer OEM protocol and Modbus protocol		
**Communication Pump ID	Pump ID range is 1-30		
**Bit rate	1200bps or 9600bps		
**Power-off memory	Return to previous status when powered on		
Dimension(Lx Wx H)	180 x 102 x 136 (mm)	185 x 125 x 136 (mm)	
Relative humidity	<80%		
Operating temperature	0°C~40°C		
Power supply	DC24V/50W	DC24V/50W	DC24V/80W
Weight	1.43kg	1.63kg	

Product Model

Note: Items with * are only available for products with dial switch and external speed control signal. Items with ** are only available for product with RS485 communication control.

T100 Series Product Model	T300 Series Product Model	T600 Series Product Model	Control Mode
T100-SV-10	T300-SV-10	T600-SV-10	Dial switch and external signal (0-10V)
T100-SA	T300-SA	T600-SA	Dial switch and external signal (4-20mA)
T100-SF	T300-SF	T600-SF	Dial switch and external signal (0-10kHz)
T100-SC	T300-SC	T600-SC	RS485 communication
T100-SV-05	T300-SV-05	T600-SV-05	Dial switch and external signal (0-5V)

Pump Head	Tubing	Max. Flow Rate Reference(mL/min)		
		T100 Series	T300 Series	T600 Series
YZ1515x, YZ II 15	13" 14" 19" 16" 25" 17" 18"	380	1140	2200
YZ2515x, YZ II 25	15" 24"	270	840	1600
FG15-13	13" 14" 19" 16" 25" 17" 18"	430	1200	2400
FG25-13	15" 24"	320	1100	2200
DMD15-13-B, DMD15-13-D	2×13" 2×14" 2×19" 2×16" 2×25"	375	1040	2070
BZ15-13-A	14"	22	80	150
BZ15-13-B	16"	80	240	460
BZ15-13-C	25"	150	470	960
BZ15-13-D	17"	270	800	1600
BZ25-13-B	24"	250	800	1600
DG15-24	16" 25" 17"	300 (Single Channel)	900 (Single Channel)	1800 (Single Channel)
DG15-28	13", 14", ID≤3.17(mm), Wall thickness:1(mm)	75 (Single Channel, speed≤100rpm)		
DG-1(6), DG-2(6)	ID≤3.17(mm), Wall thickness:0.8-1(mm)	48 (Single Channel, speed≤100rpm)		
DG-1(10), DG-2(10)	ID≤3.17(mm), Wall thickness:0.8-1(mm)	32 (Single Channel, speed≤100rpm)		

OEM Variable Speed Peristaltic Pump

SC02 Series with Integrated Driver

Max. Flow Rate

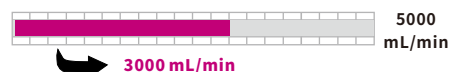

- Compact size and structure, utilizing a NEMA 23 stepper motor with an integrated driver.
- Communication control of the pump via the RS485 interface (supporting the Modbus RTU).
- Compatible with various peristaltic pump heads with a wide flow range.

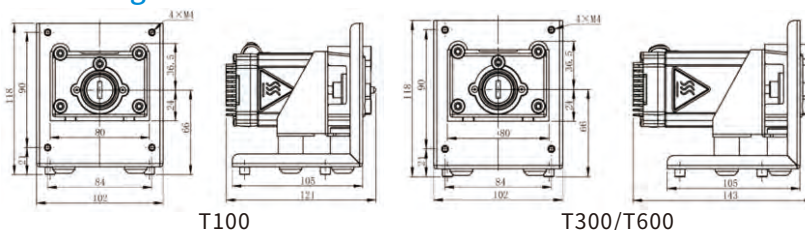

OEM PERISTALTIC PUMP

	T100-SC02-01	T300-SC02-01	T600-SC02-01
Pump Speed	0-100rpm	0-300rpm	0-600rpm
Speed resolution	Minimum speed control resolution: 0.01rpm		
Control function	RS485 interface, supporting both Modbus RTU protocol and Longer Pump OEM protocol. Control the pump speed, start/stop, running direction, and prime status (full speed) via communication commands. And the pump status when power up can be configured.		
Communication parameters	Baud rate: 1200bps, 9600bps, 19200bps, 115200bps Parity: None or Even Pump address: 1-32 Stop bit: 1 bit		
Output	DC5V 100mA		
Power supply	DC24V/15W	DC24V/45W	DC24V/55W
Dimensions(L*W*H)	121*102*118mm	143*102*118mm	
Mounting method	Panel mount or soleplate mount		
Working condition	Temperature: 0°C-40°C, relative humidity < 80%		
Weight(without pump head)	1.29kg	1.61kg	

Pump Head	Tubings	Max Flow Rate(mL/min) T100-SC02-01	Max Flow Rate(mL/min) T300-SC02-01	Max Flow Rate(mL/min) T600-SC02-01
YZ1515X,YZ1115	13#,14#,19#,16#,25#,17#,18#	380	1100	2200
YZ2515X	15#,24#	270	800	1600
YZ1125	15#,24#,35#,36#	500	1500	3000
FG15-13	13#,14#,19#,16#,25#,17#,18#	430	1200	2400
FG25-13	15#,24#	320	1100	2200
DMD15-13-B DMD15-13-D	2x13#,2x14#,2x19#,2x16#,2x25#	375	1035	2070
BZ15-13-A	14#	22	75	150
BZ15-13-B	16#	80	230	460
BZ15-14-C	25#	150	480	960
BZ15-14-D	17#	270	800	1600
BZ25-13-B	24#	250	800	1600
DG15-24	16#,25#,17#	300 (Single Channel)	900(Single Channel)	1800(Single Channel)
DG15-28	13#, 14#, ID≤3.17mm W.T. 0.8-1mm	75 (Single Channel)	Not Recommended	Not Recommended
DG-(1,2,4,6,8) 6 rollers	ID≤3.17mm W.T. 0.8-1mm	48 (Single Channel)	Not Recommended	Not Recommended
DG-(1,2,4) 10 rollers	ID≤3.17mm W.T. 0.8-1mm	32 (Single Channel)	Not Recommended	Not Recommended
BPH01	13#, 14#, 19#, 16#, 25#	82	260	530

OEM Variable Speed Peristaltic Pump

SE02 Series with Integrated Driver

Max. Flow Rate

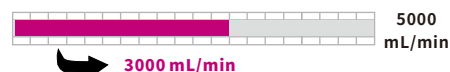

- Compact size and structure, utilizing a NEMA 23 stepper motor with an integrated driver
- Control the pump through digital signals, analog signals and pulse signals.
- Compatible with various peristaltic pump heads with a wide flow range.

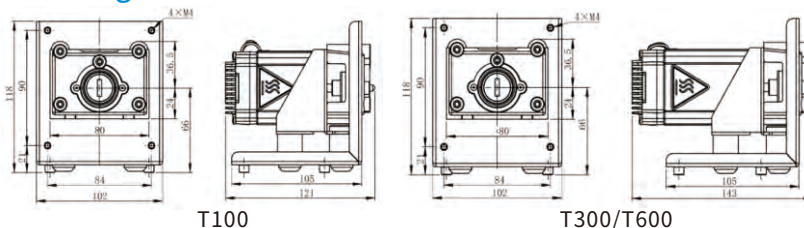

OEM PERISTALTIC PUMP

	T100-SE02-01	T300-SE02-01	T600-SE02-01
Pump Speed	0-100rpm	0-300rpm	0-600rpm
Speed resolution	0.1rpm	1rpm	1rpm
Running direction control	Pump running direction is controlled by a switch signal (dry contact signal). The trigger mode can be configured via communication commands to either level trigger or pulse trigger. Factory default setting: level trigger mode, contact open for clockwise, contact closed for counterclockwise.		
Start/stop control	Start/stop is controlled by a switch signal (dry contact signal). The trigger mode can be configured via communication commands to either level trigger or pulse trigger. Factory default setting: level trigger mode, contact open for start, contact closed for stop.		
DIP switch setting for pump speed	The DIP switch can set the pump speed to 0-100rpm, and each DIP position corresponds to a step of 5rpm.	The DIP switch can set the pump speed to 0-300rpm, and each DIP position corresponds to a step of 10rpm.	The DIP switch can set the pump speed to 0-600rpm, and each DIP position corresponds to a step of 20rpm.
External signal for pump speed	The pump speed will be proportional to the external speed signal: 4-20mA, 0-5V, 0-10V, 0-10kHz. The relationship between the signal range and speed range can be configured through communication commands.		
Output	DC5V 100mA		
Power supply	DC24V/15W	DC24V/45W	DC24V/55W
Dimensions(L*W*H)	121*102*118mm	143*102*118mm	
Mounting method	Panel mount or soleplate mount		
Working condition	Temperature: 0°C-40°C, relative humidity < 80%		
Weight(without pump head)	1.29kg	1.61kg	

Pump Head	Tubings	Max Flow Rate(mL/min) T100-SE02-01	Max Flow Rate(mL/min) T300-SE02-01	Max Flow Rate(mL/min) T600-SE02-01
YZ1515X,YZ1115	13#,14#,19#,16#,25#,17#,18#	380	1100	2200
YZ2515X	15#,24#	270	800	1600
YZ1125	15#,24#,35#,36#	500	1500	3000
FG15-13	13#,14#,19#,16#,25#,17#,18#	430	1200	2400
FG25-13	15#,24#	320	1100	2200
DMD15-13-B DMD15-13-D	2x13#,2x14#,2x19#,2x16#,2x25#	375	1035	2070
BZ15-13-A	14#	22	75	150
BZ15-13-B	16#	80	230	460
BZ15-14-C	25#	150	480	960
BZ15-14-D	17#	270	800	1600
BZ25-13-B	24#	250	800	1600
DG15-24	16#,25#,17#	300(Single Channel)	900(Single Channel)	1800(Single Channel)
DG15-28	13#,14# ID≤3.17mm W.T. 0.8-1mm	75(Single Channel)	Not Recommended	Not Recommended
DG-(1,2,4,6,8) 6 rollers	ID≤3.17mm W.T. 0.8-1mm	48(Single Channel)	Not Recommended	Not Recommended
DG-(1,2,4) 10 rollers	ID≤3.17mm W.T. 0.8-1mm	32(Single Channel)	Not Recommended	Not Recommended
BPH01	13#, 14#, 19#, 16#, 25#	82	260	530

OEM Variable Speed Peristaltic Pump

Max. Flow Rate



SC01 Series with Integrated Driver

OEM PERISTALTIC PUMP



- Compact size and structure, utilizing a NEMA 17 stepper motor with an integrated driver
- Communication control of the pump via the RS485 interface (supporting the Modbus RTU).
- Compatible with various peristaltic pump heads with a wide flow range.

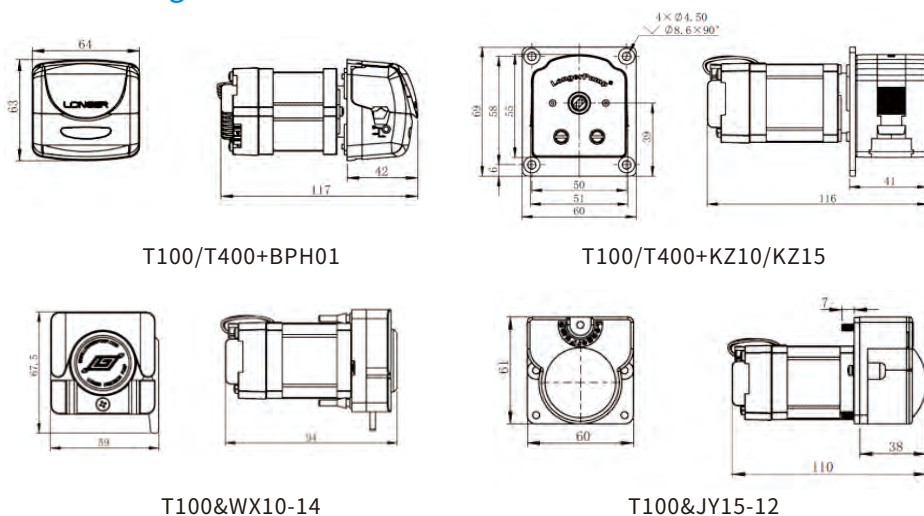

	T100-SC01&BPH01 T100-SC01&WX10-14-H	T100-SC01-02 T100-SC01&JY15-12-C	T400-SC01&BPH01 T400-SC01-02
Pump Speed	0-100rpm		0-400rpm
Speed resolution	Modbus protocol:0.01rpm Longer OEM protocol:0.1rpm		Modbus protocol: 0.01rpm Longer OEM protocol:1rpm
Control function	RS485 interface, supporting both Modbus RTU protocol and Longer Pump OEM protocol. Control the pump speed, start/stop, running direction, and prime status (full speed) via communication commands. And the pump status when power up can be configured.		
Communication parameters	Baud rate: 1200bps, 9600bps, 19200bps, 115200bps Parity: None or Even Pump address: 1-32 Stop bit: 1 bit		
Output	DC5V 10mA		
Power supply	DC24V/8W		DC24V/12W
Dimensions(L*W*H)	With BPH01 pump head: 117x64x63mm With KZ10/KZ15 pump head: 110x60x69mm With WX10-14 pump head: 94x59x67.5mm With JY15-12 pump head: 116x60x61mm		
Mounting method	Panel mount		
Working condition	Temperature: 0°C-40°C, relative humidity < 80%		
Weight	With WX10-14 pump head: 0.47kg; With BPH01/JY15/KZ10/KZ15 pump head: 0.54kg		

Pump Drive	Max Speed	Pump Head	Tubings	Max Flow Rate(mL/min)
T100-SC01-02	100rpm	KZ10	ID ≤ 3.17mm, W.T. : 0.86mm	23
		KZ15	13#, 14#, 19#, 16#	42
T400-SC01-02	400rpm	KZ10	ID ≤ 3.17mm, W.T. : 0.86mm	92
		KZ15	13#, 14#, 19#, 16#	168
T100-SC01&BPH01	100rpm	BPH01(Included)	13#, 14#, 19#, 16#, 25#	82
T400-SC01&BPH01	400rpm	BPH01(Included)	13#, 14#, 19#, 16#, 25#	340
T100-SC01&WX10-14-H	100rpm	WX10-14-H (Included)	ID ≤ 3.17mm, W.T. : 0.8-1mm	40
T100-SC01&JY15-12-C	100rpm	JY15-12-C(Included)	25#, 17#	170

OEM Variable Speed Peristaltic Pump

SE01 Series with Integrated Driver

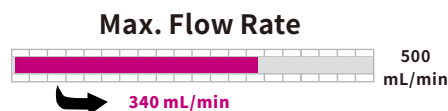

- Compact size and structure, utilizing a NEMA 17 stepper motor with an integrated driver
- Control the pump through digital signals, analog signals and pulse signals.
- Compatible with various peristaltic pump heads with a wide flow range.

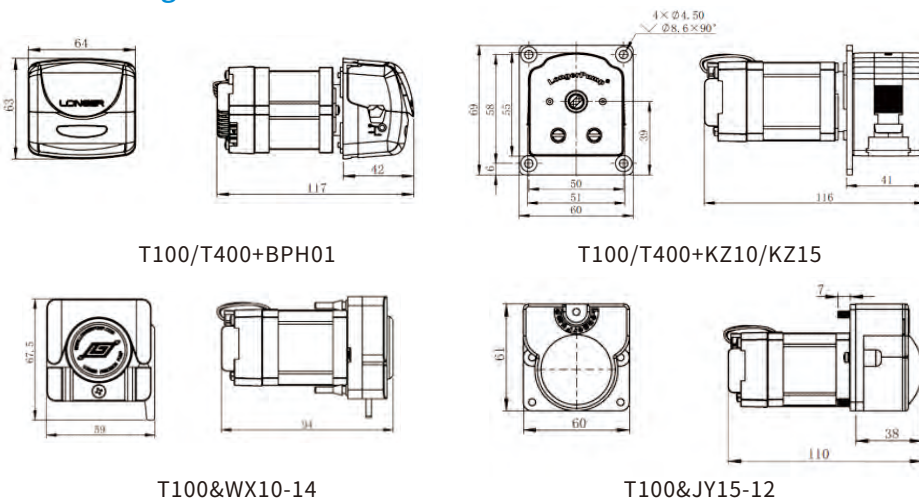

OEM PERISTALTIC PUMP

	T100-SE01&BPH01 T100-SE01&WX10-14-H	T100-SE01-02 T100-SE01&JY15-12-C	T400-SE01&BPH01 T400-SE01-02
Pump Speed	0-100rpm		0-400rpm
Speed resolution	0.1rpm		1rpm
Running direction control	Pump running direction is controlled by a switch signal (dry contact signal). The trigger mode can be configured via communication commands to either level trigger or pulse trigger. Factory default setting: level trigger mode, contact open for clockwise, contact closed for counterclockwise.		
Start/stop control	Start/stop is controlled by a switch signal (dry contact signal). The trigger mode can be configured via communication commands to either level trigger or pulse trigger. Factory default setting: level trigger mode, contact open for start, contact closed for stop.		
DIP switch setting for pump speed	The DIP switch can set the pump speed to 0-100rpm, and each DIP position corresponds to a step of 5rpm.		The DIP switch can set the pump speed to 0-400rpm, and each DIP position corresponds to a step of 20rpm.
External signals for pump speed	The pump speed will be proportional to the external speed signal: 4-20mA, 0-5V, 0-10V, 0-10kHz. The relationship between the signal range and speed range can be configured through communication commands.		
Output	DC5V 10mA		
Power supply	DC24V/8W		DC24V/12W
Dimensions(L*W*H)	With BPH01 pump head: 117x64x63mm With KZ10/KZ15 pump head: 110x60x69mm With WX10-14 pump head: 94x59x67.5mm With JY15-12 pump head: 116x60x61mm		
Mounting method	Panel mount		
Working condition	Temperature: 0°C-40°C, relative humidity<80%		
Weight	With WX10-14 pump head: 0.47kg; With BPH01/JY15/KZ10/KZ15 pump head: 0.54kg		

Pump Drive	Max Speed	Pump Head	Tubings	Max Flow Rate(mL/min)
T100-SE01-02	100rpm	KZ10	ID≤3.17mm, W.T.: 0.86mm	23
		KZ15	13#, 14#, 19#, 16#	42
T400-SE01-02	400rpm	KZ10	ID≤3.17mm, W.T.: 0.86mm	92
		KZ15	13#, 14#, 19#, 16#	168
T100-SE01&BPH01	100rpm	BPH01(Included)	13#, 14#, 19#, 16#, 25#	82
T400-SE01&BPH01	400rpm	BPH01(Included)	13#, 14#, 19#, 16#, 25#	340
T100-SE01&WX10-14-H	100rpm	WX10-14-H (Included)	ID≤3.17mm, W.T.: 0.8-1mm	40
T100-SE01&JY15-12-C	100rpm	JY15-12-C(Included)	25#, 17#	170

OEM Variable Speed Peristaltic Pump

Max. Flow Rate



DC Brushless Motor Series

OEM PERISTALTIC PUMP



L500E-B012C-1
L500I-B012C-1
L500E-B024C-1
L500I-B024C-1



L500E-B012C-2
L500I-B012C-2
L500E-B024C-2
L500I-B024C-2

- Brushless DC motor with built in controller has better reliability, longer life time and much lower noise.
- Simple to control the speed by potentiometer or 0-4V analogue signal.
- Fitted with different pump heads.
- Soleplate or panel installation.

Pump Specification

Items	Specification
Speed	50rpm-500rpm, CW/CCW
Speed resolution	1rpm
Direction control	Direction is controlled by external switch signal. CW when switch is closed, CCW when switch is open.
Start/stop control	Start/stop is controlled by external switch signal. Pump runs when switch is closed, stops when switch is open.
Speed control	Built-in, Potentiometer control or 0-4V analogue signal control
Brake	The function of motor brake in second is controlled by external switch signal. Motor brakes when switch is closed.
Operating Temperature	0 to 40°C < 80°C
Relative humidity	12VDC/80W or 24VDC/80W
Power supply	Pump drive for YZ pump head: 2.33kg
Weight	Pump drive for KZ10/KZ15 pump head: 2.03kg

Installation Drawing

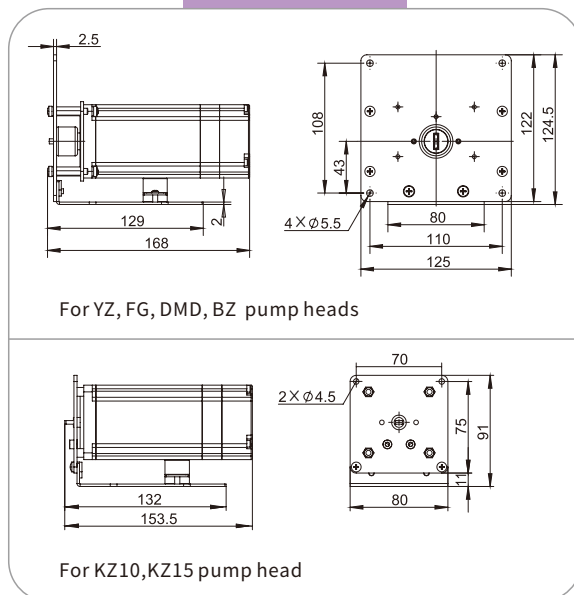

Model (Product code, Speed control, Power supply)	Pump head	Tubing	Max. Flow Rate (mL/min)	Weight (kg)
L500E-B012C-1 (05.71.100, 0-4V, 12VDC)	YZ1515x, YZ1115	13" 14" 19" 16" 25" 17" 18"	1830	2.73
	YZ2515x	15" 24"	1330	
	YZ1125	15" 24" 35" 36" (36" only can be used for the pump with 24VDC)	1830(pump with 12VDC) 2500(pump with 24VDC)	
L500I-B012C-1 (05.71.101, [knob], 12VDC)	FG15-13	13" 14" 19" 16" 25" 17" 18"	1790	2.61
	FG25-13	15" 24"	1600	
L500E-B024C-1 (05.71.102, 0-4V, 24VDC)	DMD15-13-B, DMD15-13-D	2×13" 2×14" 2×19" 2×16"	800	2.76
	BZ15-13-A	14"	125	
L500I-B024C-1 (05.71.103, [knob], 24VDC)	BZ15-13-B	16"	380	2.64
	BZ15-13-C	25"	800	
	BZ15-13-D	17"	1340	
	BZ25-13-B	24"	2340	
L500E-B012C-2(05.71.104, 0-4V, 12VDC) L500I-B012C-2(05.71.105, [knob], 12VDC)	(1, 2, 3, 4) × KZ15-14 (Max.Speed: 450rpm)	13" 14" 19" 16"	190	2.13-2.43
L500E-B024C-2(05.71.106, 0-4V, 24VDC) L500I-B024C-2(05.71.107, [knob], 24VDC)	(1, 2, 3, 4) × KZ10-24 (Max.Speed: 450rpm)	ID≤2.79mm Wall thickness 0.86mm	104	

*Note: [knob]--Potentiometer with knob.

OEM Variable Speed Peristaltic Pump

Max. Flow Rate

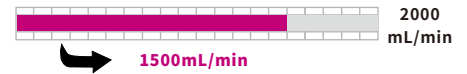

DC Brushless Motor Series

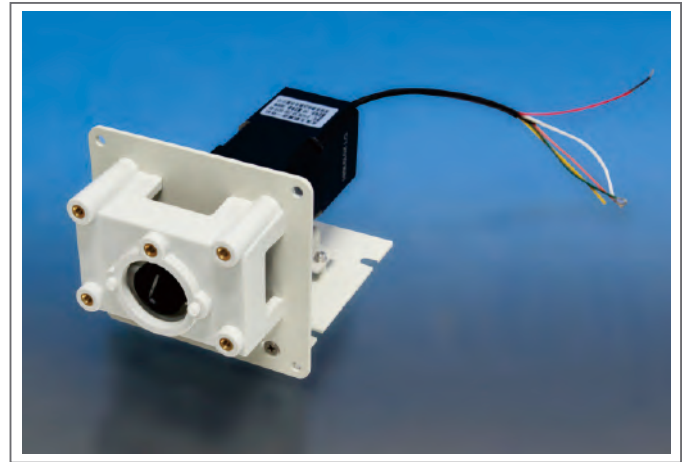
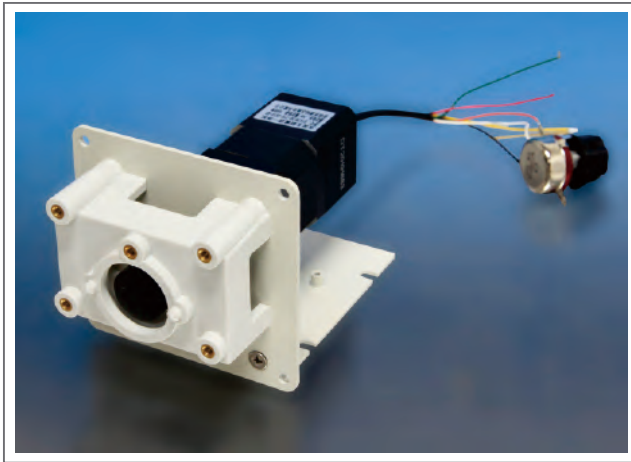

- Brushless DC motor with built in controller has better reliability and longer life.
- Fitted with different pump heads and support stacked pump heads for multichannel.
- Mainly for OEM instrument and equipment.
- Soleplate or panel installation.

Installation Drawing

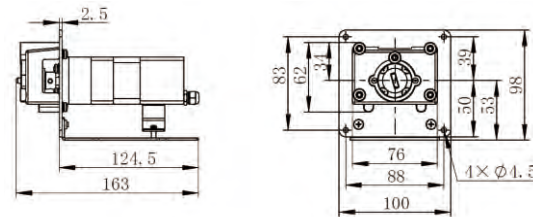

Pump Specification

Product Model	T100-BV-24	T100-BM-24	T300-BV-24	T300-BM-24
Speed	0rpm-100rpm, CW/CCW		0rpm-300rpm, CW/CCW	
Speed resolution	1rpm			
Start/stop control	Start/stop is controlled by external switch signal. Pump runs when switch is closed, stops when switch is open			
Direction control	Direction is controlled by external switch signal. CCW when switch is closed, CW when switch is open			
Speed control	0-5V analogue signal control	Potentiometer control	0-5V analogue signal control	Potentiometer control
Dimension(L×W×H)	163x100x98(mm)			
Operating temperature	0°C~40°C			
Relative humidity	≤80°C			
Power supply	24VDC/50W		24VDC/80W	
Weight	1.01kg			

Applicable Pump Head	Tubing	Max Flow Rate Reference(ml/min)		Weight with pump head (kg)
		T100-BV-24, T100-BM-24	T300-BV-24, T300-BM-24	
(1,2,3) ×YZ1515x	13 [#] 14 [#] 19 [#] 16 [#] 25 [#] 17 [#] 18 [#]	380(single channel)	1140(single channel)	1.41-2.21
(1,2,3) ×YZ1115	13 [#] 14 [#] 19 [#] 16 [#] 25 [#] 17 [#] 18 [#]	380(single channel)	1140(single channel)	1.36-2.06
(1,2,3) ×YZ2515x	15 [#] 24 [#]	270(single channel)	840(single channel)	1.41-2.21
YZ1125	15 [#] 24 [#] 35 [#] 36 [#]	500(single channel)	1500(single channel)	1.41
FG15-13-B	13 [#] 14 [#] 19 [#] 16 [#] 25 [#] 17 [#] 18 [#]	430	1290	1.29
FG25-13-B	15 [#] 24 [#]	320	960	1.29
DMD15-13-B/DMD15-13-D	2 × 13 [#] 2 × 14 [#] 2 × 19 [#] 2 × 16 [#] 2 × 25 [#]	375	1125	1.44
BZ15-13-A	14 [#]	22	66	1.32
BZ15-13-B	16 [#]	80	240	1.32
BZ15-13-C	25 [#]	150	450	1.32
BZ15-13-D	17 [#]	270	810	1.32
BZ25-13-B	24 [#]	250	750	1.32
DG-(1,2,4,6,8)6 rollers	ID≤3.17mm Wall thickness0.8-1mm	48 (single channel)	Not applicable	1.21-1.64
DG-(1,2,4,6,8)10 rollers	ID≤3.17mm Wall thickness0.8-1mm	32 (single channel)	Not applicable	1.22-1.68

OEM Fixed Speed Peristaltic Pump

Max. Flow Rate

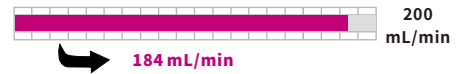

TH15 Series

OEM PERISTALTIC PUMP

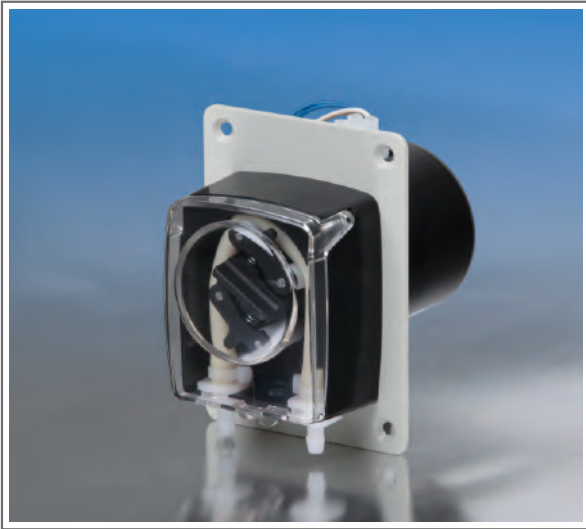

AC Synchronous Motor Outline Drawing



DC/AC Motor Outline Drawing

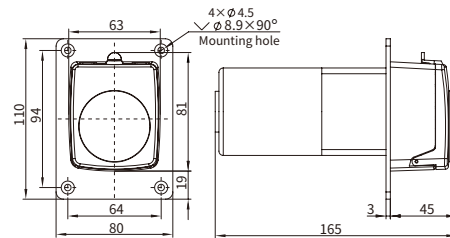
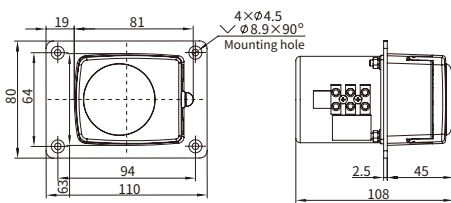

Model	Installation Mode	Product Code	Speed (rpm)	Motor	Power Supply	Speed Tolerance	Motor Life	Operating Temperature	Relative Humidity
G14-D2&TH15	Panel	05.52.01A	14	60 DC gear motor	DC 12V/15W	≤ ±10%	2000 hours	0 to 40°C	< 80%
G28-D2&TH15		05.52.02A	28						
G56-D2&TH15		05.52.03A	56						
G93-D2&TH15		05.52.04A	93						
G15-D102&TH15		05.54.01A	15						
G30-D102&TH15		05.54.02A	30						
G57-D102&TH15		05.54.03A	57	60 AC gear motor	AC 220V/10W				
G98-D102&TH15		05.54.04A	98						
G15-A2&TH15		05.56.21A	15						
G30-A2&TH15		05.56.22A	30						
G60-A2&TH15		05.56.23A	60						
G100-A2&TH15		05.56.24A	100						
G5-A102&TH15		05.56.01A	5	60 AC synchronous motor	AC 220V/14W				
G15-A102&TH15		05.56.02A	15						
G30-A102&TH15		05.56.03A	30						
G50-A102&TH15		05.56.04A	50						
G60-A102&TH15		05.56.05A	60						
G110-A102&TH15		05.56.11A	110						

Motor	DC Gear Motor								AC Gear Motor				AC synchronous Gear Motor					
Power Supply	DC 12V				DC 24V				AC 220V				AC 220V					
Speed(rpm)	14	28	56	93	15	30	57	98	15	30	60	100	5	15	30	50	60	110
Tubing	Flow Rate(mL/min)																	
13"	1	2	4	7	1	2	4	7	1	2	4	7	0	1	2	4	4	8
14"	3	6	12	20	3	7	13	22	3	7	14	22	1	3	7	11	13	24
19"	7	14	28	47	8	15	30	49	8	15	31	50	3	8	15	25	30	55
16"	11	22	45	74	12	24	47	78	12	24	50	80	4	12	24	40	48	88
25"	23	47	94	155	25	50	99	164	25	50	104	167	8	25	50	84	100	184

OEM Fixed Speed Peristaltic Pump

60 Series

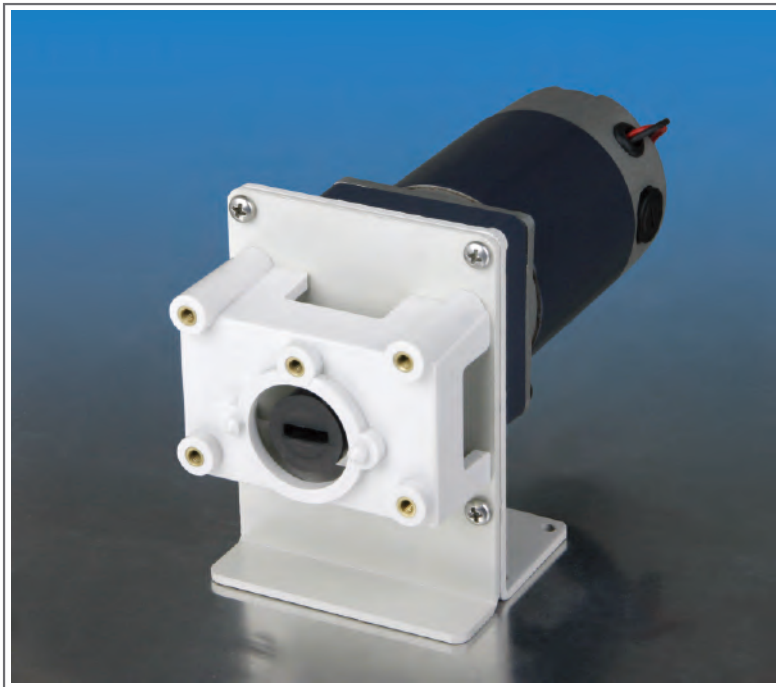

Installation Drawing

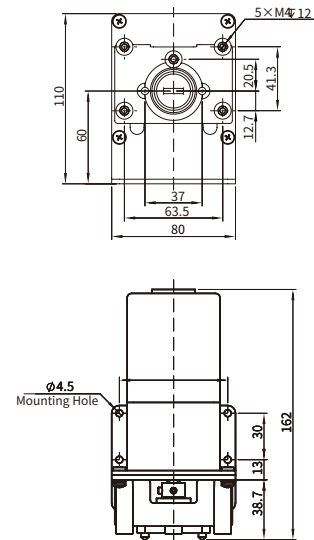

OEM PERISTALTIC PUMP

Pump Head Options



YZ1515x, YZ2515x



YZ1115, YZ1125



FG15-13, FG25-13



BZ25, BZ15



DG-1, DG-2
DG-4, DG-6

Model	Installation Mode	Product Code	Speed (rpm)	Motor	Power Supply	Speed Tolerance	Motor Life	Operating Temperature	Relative Humidity				
G14-D1	Soleplate Panel	05.51.011	14	60 DC gear motor	DC 12V/24W	$\leq \pm 10\%$	2000 hours	0 to 40°C	< 80%				
G14-D2	Panel	05.51.012	14										
G28-D1	Soleplate Panel	05.51.031	28										
G28-D2	Panel	05.51.032	28										
G56-D1	Soleplate Panel	05.51.041	56										
G56-D2	Panel	05.51.042	56										
G93-D1	Soleplate Panel	05.51.051	93										
G93-D2	Panel	05.51.052	93										
G186-D1	Soleplate Panel	05.51.311	186										
G186-D2	Panel	05.51.312	186										
G15-D101	Soleplate Panel	05.53.011	15		60 AC gear motor		AC 220V/33W			$\leq \pm 10\%$	5000 hours	0 to 40°C	< 80%
G15-D102	Panel	05.53.012	15										
G30-D101	Soleplate Panel	05.53.021	30										
G30-D102	Panel	05.53.022	30										
G59-D101	Soleplate Panel	05.53.031	59										
G59-D102	Panel	05.53.032	59										
G99-D101	Soleplate Panel	05.53.041	99										
G99-D102	Panel	05.53.042	99										
G196-D101	Soleplate Panel	05.53.311	196										
G196-D102	Panel	05.53.312	196										
G15-A1	Soleplate Panel	05.55.011	15	60 AC gear motor	AC 220V/33W	$\leq \pm 10\%$	5000 hours	0 to 40°C	< 80%				
G15-A2	Panel	05.55.012	15										
G30-A1	Soleplate Panel	05.55.021	30										
G30-A2	Panel	05.55.022	30										
G60-A1	Soleplate Panel	05.55.071	60										
G60-A2	Panel	05.55.072	60										
G88-A1	Soleplate Panel	05.55.041	88										
G88-A2	Panel	05.55.042	88										
G147-A1	Soleplate Panel	05.55.311	147										
G147-A2	Panel	05.55.312	147										

Max. Flow Rate



Parameters Table

Pump Head		DG-(1, 2, 4, 6) 6 Rollers			DG-(1, 2, 4, 6) 10 Rollers					
Tubing		1×1	2×1	3×1	1×1	2×1	3×1			
Speed(rpm)	Power Supply	Flow Rate(mL/min)								
14	DC 12V	1	4	7	1	3	4			
28		2	8	13	2	6	9			
56		4	16	27	3	12	18			
93		7	26	45	6	20	30			
15	DC 24V	1	4	7	1	3	5			
30		2	8	14	2	7	10			
59		5	17	28	4	13	19			
99		8	28	48	6	22	32			
15	AC 220V	1	4	7	1	3	5			
30		2	8	14	2	7	10			
62		5	17	30	4	14	20			
88		7	25	42	5	19	28			
Pump Head		YZ1515x,YZ1115								
Tubing		13 [#]	14 [#]	19 [#]	16 [#]	25 [#]	17 [#]	18 [#]		
Speed(rpm)	Power Supply	Flow Rate(mL/min)								
14	DC 12V	1	4	6	11	22	37	51		
28		2	7	12	21	45	75	103		
56		4	14	23	43	90	149	205		
93		6	23	39	71	149	248	341		
186		12	47	78	143	298	—	—		
15	DC 24V	1	4	6	12	24	40	55		
30		2	8	13	23	48	80	110		
59		4	15	25	45	94	157	216		
99		6	25	41	76	158	264	363		
196		12	49	82	150	314	—	—		
15	AC 220V	1	4	6	12	24	40	55		
30		2	8	13	23	48	80	110		
62		4	16	26	48	99	165	227		
88		6	22	37	67	141	235	323		
147		9	37	61	113	235	—	—		
Pump Head		YZ2515x,YZ1125		BZ25	BZ15-13-A	BZ15-13-B	BZ15-13-C	BZ15-13-D		
Tubing		15 [#]	24 [#]	24 [#]	14 [#]	16 [#]	25 [#]	17 [#]		
Speed(rpm)	Power Supply	Flow Rate(mL/min)								
14	DC 12V	22	37	37	4	11	22	37		
28		45	75	75	7	21	45	75		
56		90	149	149	14	43	90	149		
93		149	248	248	23	71	149	248		
186		—	—	—	47	143	298	—		
15	DC 24V	24	40	40	4	12	24	40		
30		48	80	80	8	23	48	80		
59		94	157	157	15	45	94	157		
99		158	264	264	25	76	158	264		
196		—	—	—	49	150	314	—		
15	AC 220V	24	40	40	4	12	24	40		
30		48	80	80	8	23	48	80		
62		99	165	165	16	48	99	165		
88		141	235	235	22	67	141	235		
147		—	—	—	37	113	235	—		
Pump Head		FG15-13-B							FG25-13-B	
Tubing		13 [#]	14 [#]	19 [#]	16 [#]	25 [#]	17 [#]	18 [#]	15 [#]	24 [#]
Speed(rpm)	Power Supply	Flow Rate(mL/min)								
14	DC 12V	1	4	9	15	31	46	50	26	41
28		2	8	19	31	62	92	100	53	82
56		4	15	37	62	125	185	200	106	165
93		6	26	62	105	207	308	333	176	275
186		12	51	124	210	415	616	666	364	574
15	DC 24V	1	4	10	17	33	49	53	28	44
30		2	8	20	34	67	99	107	57	88
59		4	16	39	66	131	195	211	112	174
99		6	27	66	112	221	328	354	188	293
196		12	54	130	222	437	650	702	384	605
15	AC 220V	1	4	10	17	33	49	53	28	44
30		2	8	20	34	67	99	107	57	88
62		4	17	41	70	138	205	222	117	183
88		6	24	59	99	196	291	315	167	260
147		9	54	98	166	328	487	—	—	—

OEM PERISTALTIC PUMP

OEM Fixed Speed Peristaltic Pump

80 Series

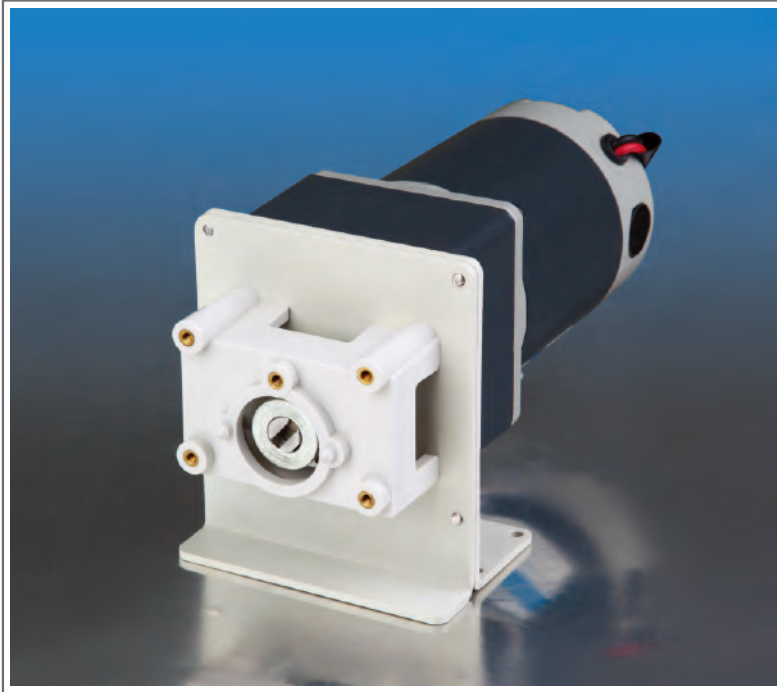

Installation Drawing

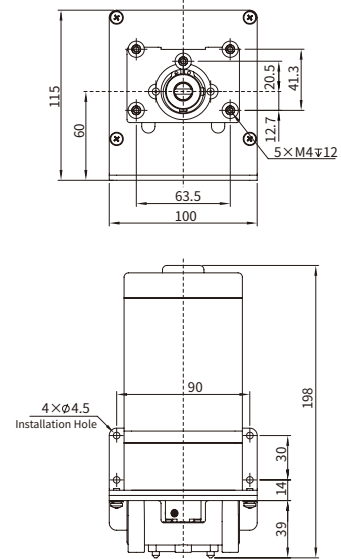

OEM PERISTALTIC PUMP

Pump Head Options



YZ1515x, YZ2515x

YZ1115, YZ1125

FG15-13
FG25-13

BZ25, BZ15

DG15-24

Model	Installation Mode	Product Code	Speed (rpm)	Motor	Power Supply	Speed Tolerance	Motor Life	Operating Temperature	Relative Humidity
G186-D3	Soleplate Panel	05.51.313	186	80 DC gear motor	DC 12V/40W	$\leq \pm 10\%$	2000 hours	0 to 40°C	<80%
G186-D4	Panel	05.51.314	186						
G311-D3	Soleplate Panel	05.51.511	311						
G311-D4	Panel	05.51.512	311						
G560-D3	Soleplate Panel	05.51.721	560						
G560-D4	Panel	05.51.722	560						
G196-D103	Soleplate Panel	05.53.313	196		DC 24V/40W				
G196-D104	Panel	05.53.314	196						
G327-D103	Soleplate Panel	05.53.511	327						
G327-D104	Panel	05.53.512	327						
G590-D103	Soleplate Panel	05.53.711	590						
G590-D104	Panel	05.53.712	590						
G147-A3	Soleplate Panel	05.55.313	147	80 AC gear motor	AC 220V/40W	5000 hours			
G147-A4	Panel	05.55.314	147						
G220-A3	Soleplate Panel	05.55.411	220						
G220-A4	Panel	05.55.412	220						
G366-A3	Soleplate Panel	05.55.511	366						
G366-A4	Panel	05.55.512	366						

Max. Flow Rate



Parameters Table

Pump Head		DG15-24								
Tubing		16"	25"	17"						
Speed(rpm)	Power Supply	Flow Rate(mL/min)								
186	DC 12V	152	357	558						
311		254	596	933						
560		457	1073	1680						
196	DC 24V	160	376	588						
327		267	627	981						
590		482	1131	1770						
147	AC 220V	120	282	441						
220		180	422	660						
366		299	702	1098						
Pump Head		YZ1515x, YZ1115								
Tubing		13"	14"	19"	16"	25"	17"	18"		
Speed(rpm)	Power Supply	Flow Rate(mL/min)								
186	DC 12V	12	47	78	143	298	496	682		
311		20	78	130	238	498	829	1140		
560		35	140	233	429	896	1493	2053		
196	DC 24V	12	49	82	150	314	523	719		
327		21	82	136	251	523	872	1199		
590		37	148	246	452	944	1573	2163		
147	AC 220V	9	37	61	113	235	392	539		
220		14	55	92	169	352	587	807		
366		23	92	153	281	586	976	1342		
Pump Head		YZ2515x, YZ1125		BZ25	BZ15-13-A	BZ15-13-B	BZ15-13-C	BZ15-13-D		
Tubing		15"	24"	24"	14"	16"	25"	17"		
Speed(rpm)	Power Supply	Flow Rate(mL/min)								
186	DC 12V	298	496	496	47	143	298	496		
311		498	829	829	78	238	498	829		
560		896	1493	1493	140	429	896	1493		
196	DC 24V	314	523	523	49	150	314	523		
327		523	872	872	82	251	523	872		
590		944	1573	1573	148	452	944	1573		
147	AC 220V	235	392	392	37	113	235	392		
220		352	587	587	55	169	352	587		
366		586	976	976	92	281	586	976		
Pump Head		FG15-13-B							FG25-13-B	
Tubing		13"	14"	19"	16"	25"	17"	18"	15"	24"
Speed(rpm)	Power Supply	Flow Rate(mL/min)								
186	DC 12V	12	51	9	210	415	616	666	364	574
311		20	86	207	352	694	1031	1114	663	1074
560		35	154	373	634	1250	1857	2006	1251	1820
196	DC 24V	12	54	130	222	437	650	702	384	605
327		21	90	218	370	730	1084	1171	697	1130
590		37	162	393	668	1317	1956	2114	1340	1907
147	AC 220V	9	40	98	166	328	487	526	288	454
220		14	61	146	249	491	729	788	458	688
366		23	101	244	414	817	1213	1311	781	1265

OEM Fixed Speed Peristaltic Pump

90-1 Series

Max. Flow Rate

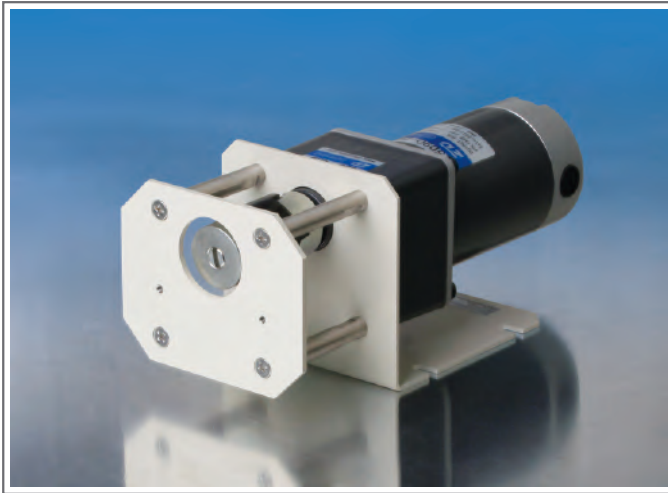

Pump Head KZ25

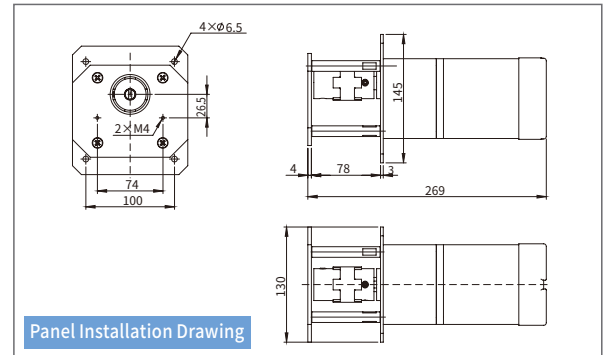
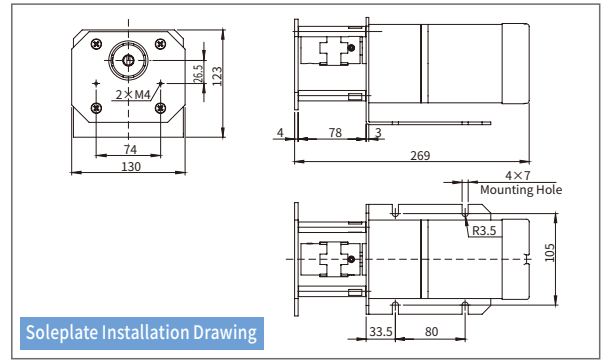

OEM PERISTALTIC PUMP

Model	Installation Mode	Product Code	Speed (rpm)	Motor	Power Supply	Speed Tolerance	Motor Life	Operating Temperature	Relative Humidity
G200-D5	Soleplate Panel	05.51.411	200	90 DC gear motor	DC 12V/90W	≤ ±10%	2000 hours	0 to 40°C	<80%
G200-D6	Panel	05.51.412	200						
G240-D5	Soleplate Panel	05.51.421	240						
G240-D6	Panel	05.51.422	240						
G333-D5	Soleplate Panel	05.51.521	333						
G333-D6	Panel	05.51.522	333						
G500-D5	Soleplate Panel	05.51.711	500						
G500-D6	Panel	05.51.712	500						
G200-D105	Soleplate Panel	05.53.411	200						
G200-D106	Panel	05.53.412	200						
G240-D105	Soleplate Panel	05.53.421	240						
G240-D106	Panel	05.53.422	240						
G333-D105	Soleplate Panel	05.53.521	333						
G333-D106	Panel	05.53.522	333						
G500-D105	Soleplate Panel	05.53.721	500						
G500-D106	Panel	05.53.722	500						
G208-A5	Soleplate Panel	05.55.421	208	90 AC gear motor	AC 220V/90W		5000 hours		
G208-A6	Panel	05.55.422	208						
G250-A5	Soleplate Panel	05.55.431	250						
G250-A6	Panel	05.55.432	250						
G347-A5	Soleplate Panel	05.55.521	347						
G347-A6	Panel	05.55.522	347						
G417-A5	Soleplate Panel	05.55.611	417						
G417-A6	Panel	05.55.612	417						

Power Supply	DC 12V, DC 24V				AC 220V			
Speed(rpm)	200	240	333	500	208	250	347	417
Tubing	Flow Rate(mL/min)							
15"	600	720	999	1500	624	750	1041	1251
24"	1167	1400	1943	2917	1213	1458	2024	2433
35"	1667	2000	2775	4167	1733	2083	2892	3475
36"	2000	2400	3330	5000	2080	2500	3470	4170

OEM Fixed Speed Peristaltic Pump

90-2 Series

Max. Flow Rate



OEM PERISTALTIC PUMP

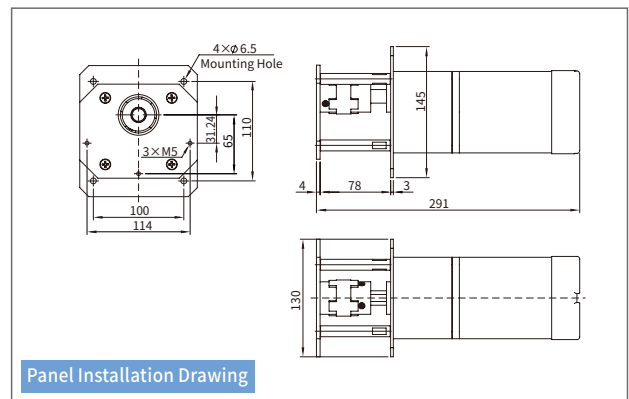
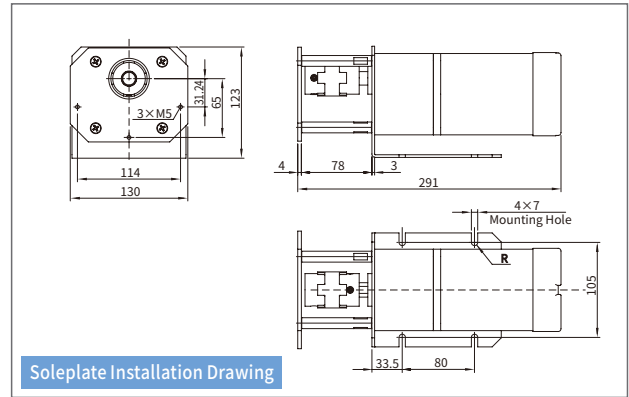
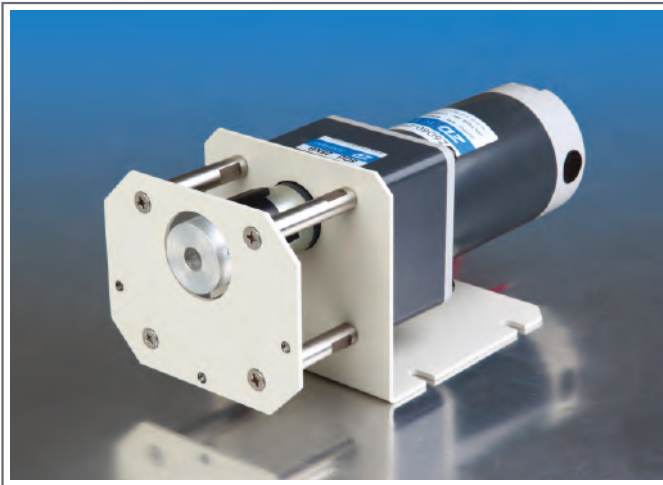

Pump Head Options



Model	Installation Mode	Product Code	Speed (rpm)	Motor	Power Supply	Speed Tolerance	Motor Life	Operating Temperature	Relative Humidity
G240-D7	Soleplate Panel	05.51.423	240	90 DC gear motor	DC 12V/90W	≤ ±10%	2000 hours	0 to 40°C	< 80%
G240-D8	Panel	05.51.424	240						
G333-D7	Soleplate Panel	05.51.523	333						
G333-D8	Panel	05.51.524	333						
G440-D7	Soleplate Panel	05.51.611	440						
G440-D8	Panel	05.51.612	440						
G500-D7	Soleplate Panel	05.51.713	500						
G500-D8	Panel	05.51.714	500						
G208-D107	Soleplate Panel	05.53.431	208						
G208-D108	Panel	05.53.432	208						
G288-D107	Soleplate Panel	05.53.441	288						
G288-D108	Panel	05.53.442	288						
G346-D107	Soleplate Panel	05.53.531	346						
G346-D108	Panel	05.53.532	346						
G466-D107	Soleplate Panel	05.53.611	466						
G466-D108	Panel	05.53.612	466						
G166-A7	Soleplate Panel	05.55.321	166	90 AC gear motor	AC 220V/90W		5000 hours		
G166-A8	Panel	05.55.322	166						
G250-A7	Soleplate Panel	05.55.433	250						
G250-A8	Panel	05.55.434	250						
G347-A7	Soleplate Panel	05.55.523	347						
G347-A8	Panel	05.55.524	347						
G417-A7	Soleplate Panel	05.55.613	417						
G417-A8	Panel	05.55.614	417						

Power Supply	DC 12V				DC 24V				AC 220V			
Speed (rpm)	240	333	440	500	208	208	346	466	166	250	347	417
Tubing	Flow Rate (mL/min)											
73"	2400	3330	4400	5000	2080	2080	3460	4660	1660	2500	3470	4170
82"	4400	6105	8067	9167	3813	3813	6343	8543	3043	4583	6362	7645

Peristaltic Pump Tubing

Common Tubing Material

Silicone tubing: Ultra-smooth inner liner with extremely low leachables, low protein absorption, good flexibility and wide temperature range -51 to 238°C.

Various materials tubings are available.

Tubing Specifications:

Micro & small flow tubing

Tubing Sizes	0.13×0.9	0.51×0.9	0.76×0.85	1.52×0.85	2.06×0.85	3.17×0.85	0.5×0.8	1×1	2×1	2.4×0.8	3×1
Tubing cross sections (1:1)											
Wall thickness (mm)	0.9		0.85				0.8	1		0.8	1
Inner diameter (mm)	0.13	0.51	0.76	1.52	2.06	3.17	0.5	1	2	2.4	3
Maximum pressure (Mpa)	Continuous					0.1					
	Intermittent					0.1					

TUBING

Medium flow tubing (Longerpump silicone tubing)

Tubing Sizes	13 [#]	14 [#]	19 [#]	16 [#]	25 [#]	17 [#]	18 [#]	15 [#]	24 [#]	35 [#]	36 [#]	
Tubing cross sections (1:1)												
Wall thickness of domestic tubing (mm)	1.7			1.6				2.4				
Wall thickness of imported tubing (inch)	1/16"						3/32"					
Inner diameter of domestic tubing (mm)	0.8	1.6	2.4	3.2	4.8	6.4	7.9	4.8	6.4	7.9	9.5	
Inner diameter of imported tubing (inch)	1/32"	1/16"	3/32"	1/8"	3/16"	1/4"	5/16"	3/16"	1/4"	5/16"	3/8"	
Maximum pressure (Mpa)	Continuous			0.17		0.14	0.10	0.07	0.17		0.14	
	Intermittent			0.27		0.24	0.14	0.10	0.27		0.24	

Industrial tubing (Longerpump silicone tubing)

Tubing Sizes	73 [#]	82 [#]	88 [#]	92 [#]
Tubing cross sections (1:1)				
Wall thickness of domestic tubing (mm)	3.3		4.8	
Wall thickness of imported tubing (inch)	1/8"		3/16"	
Inner diameter of domestic tubing (mm)	9.6	12.7	12.7	25.4
Inner diameter of imported tubing (inch)	3/8"	1/2"	1/2"	1"
Maximum pressure (Mpa)	Continuous		0.14	
	Intermittent		0.14	

LongerPump® Silicone Tubing

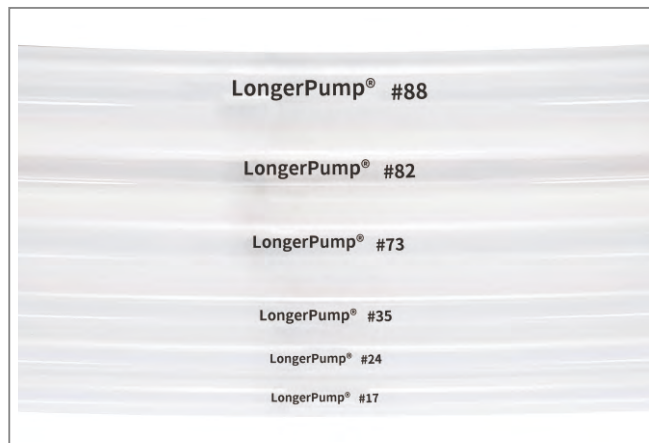

TUBING

Tubing Size	ID (mm)	OD (mm)	Wall Thickness (mm)	Length (m/pkg)	Hardness (Shore A)	Tensile Strength (MPa)	Elongation at Break (%)	Tear Strength (kN/m)	Material
13#	0.8	4.2	1.7	2/5/15	50-55	≥7.0	≥300	≥30	Platinum-cured silicone
14#	1.6	5	1.7	2/5/15	50-55	≥7.0	≥500	≥30	
19#	2.4	5.8	1.7	2/5/15	50-55	≥7.0	≥500	≥30	
16#	3.2	6.4	1.6	2/5/15	50-55	≥7.0	≥500	≥30	
25#	4.8	8	1.6	2/5/15	50-55	≥7.0	≥500	≥30	
17#	6.4	9.6	1.6	2/5/15	50-55	≥7.0	≥500	≥30	
18#	7.9	11.1	1.6	2/5/15	50-55	≥7.0	≥500	≥30	
15#	4.8	9.6	2.4	2/5/15	50-55	≥7.0	≥500	≥30	
24#	6.4	11.2	2.4	2/5/15	50-55	≥7.0	≥500	≥30	
35#	7.9	12.7	2.4	2/5/15	56-60	≥7.0	≥300	≥30	
36#	9.5	14.3	2.4	2/5/15	56-60	≥7.0	≥300	≥30	
73#	9.5	16.1	3.3	2/5/15	50-55	≥7.0	≥500	≥30	
82#	12.7	19.3	3.3	2/5/15	50-55	≥7.0	≥500	≥30	
88#	12.7	22.3	4.8	2/5/15	56-60	≥7.0	≥300	≥30	
92#	25.4	35	4.8	2/5/15	50-55	≥7.0	≥500	≥30	

* Temperature range: -30°C to 250°C * Packaging standard: Single-layer packaging

Flow Reference Curve

TUBING

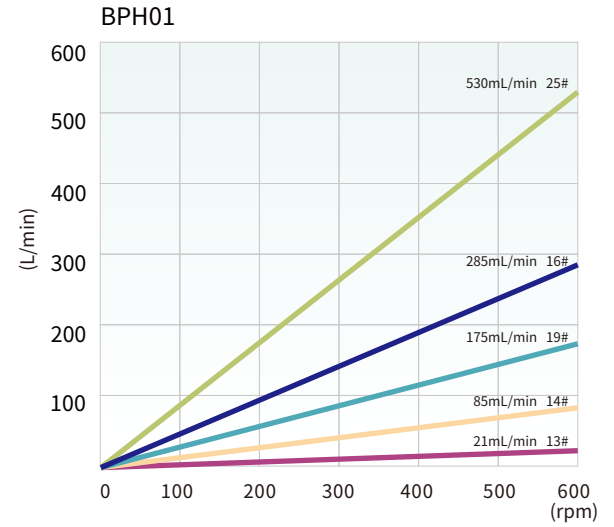
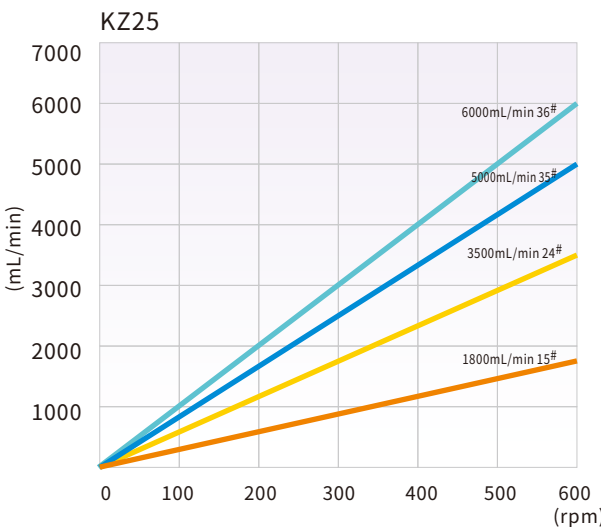
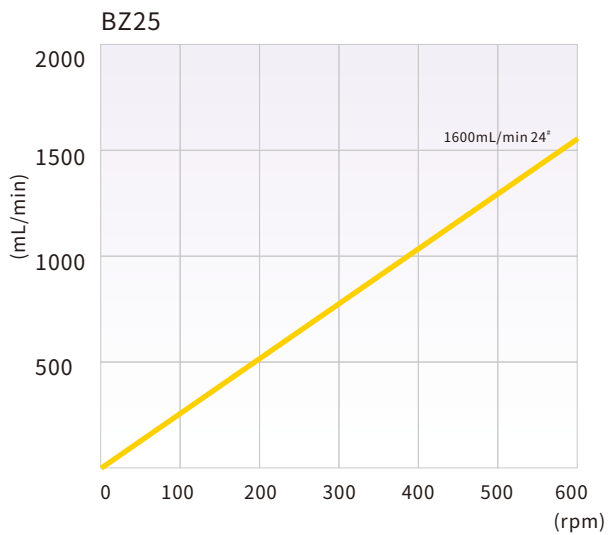
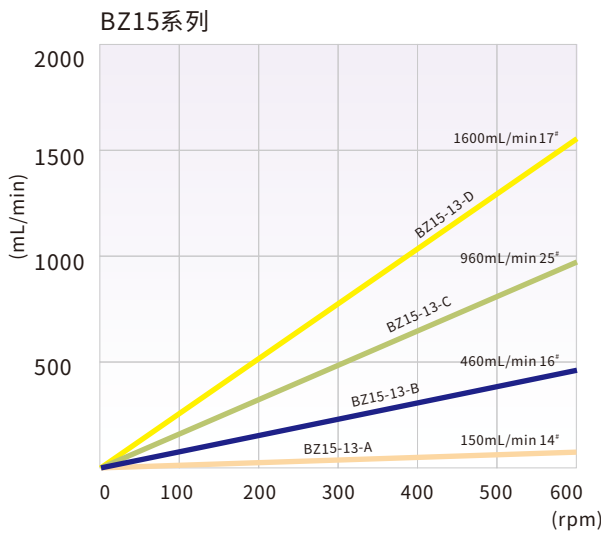
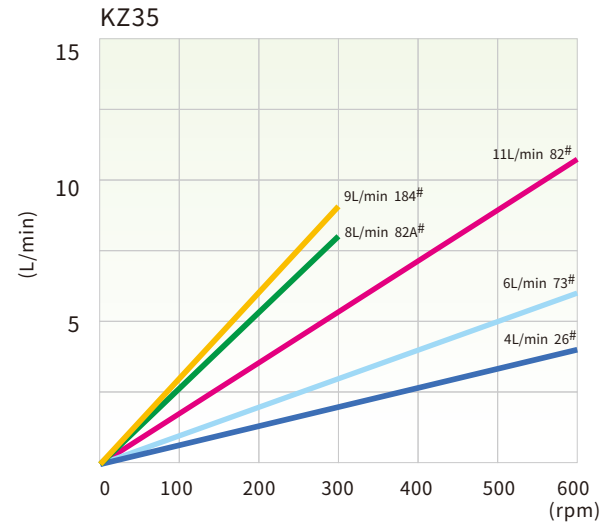
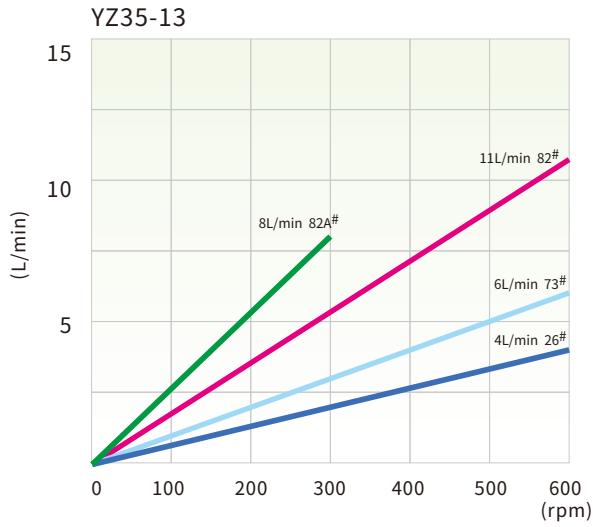

Flow Reference Curve

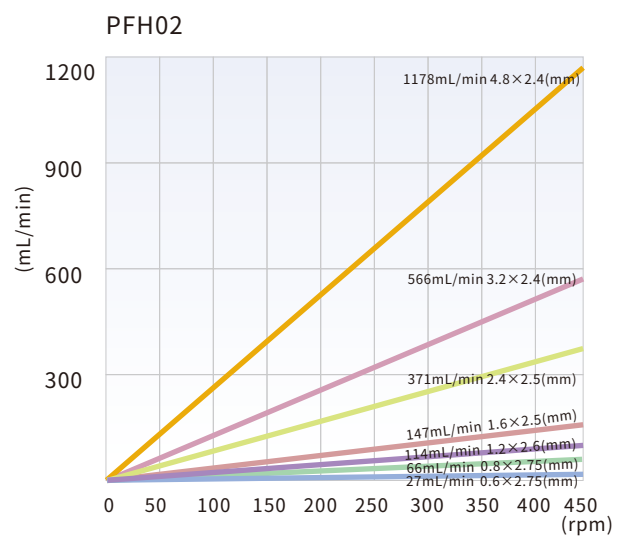
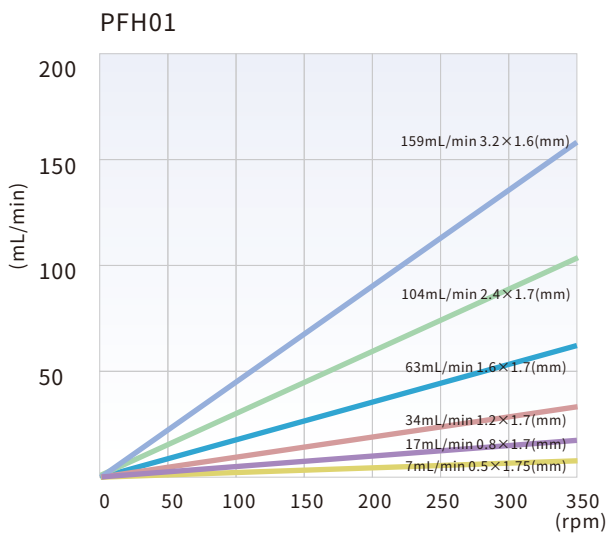
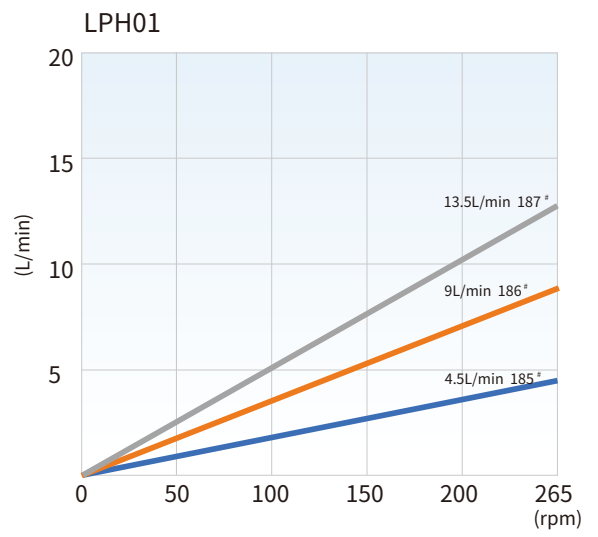
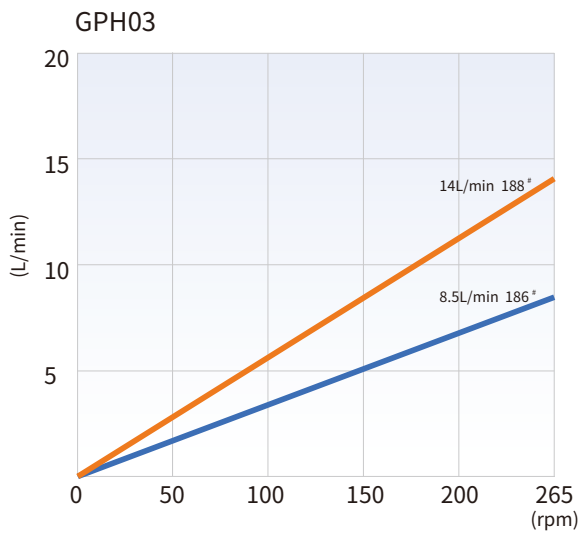
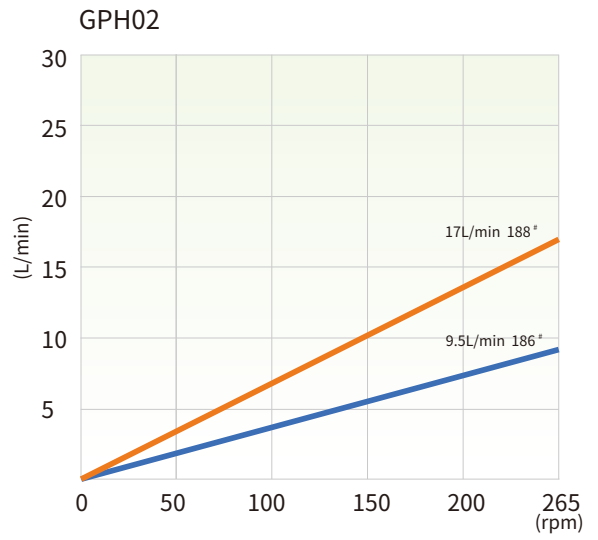
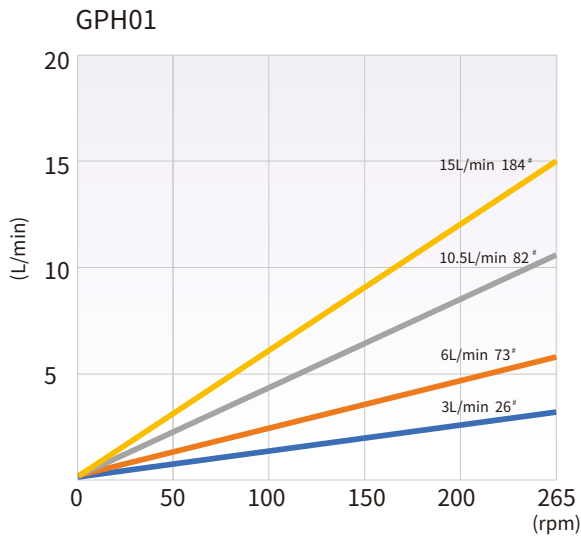

Flow Reference Curve

DG Series (6Rollers)

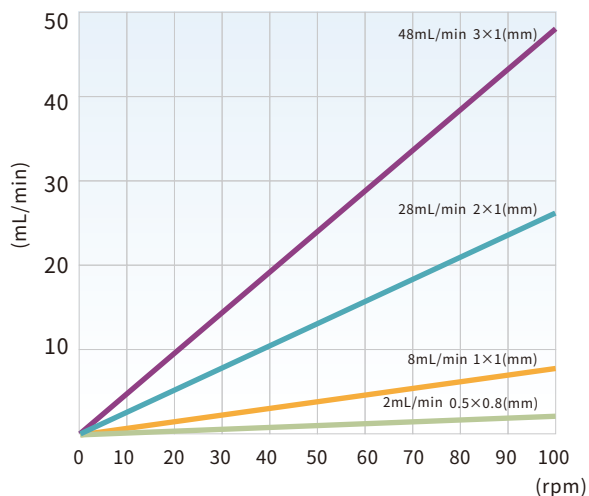

DG Series (10Rollers)

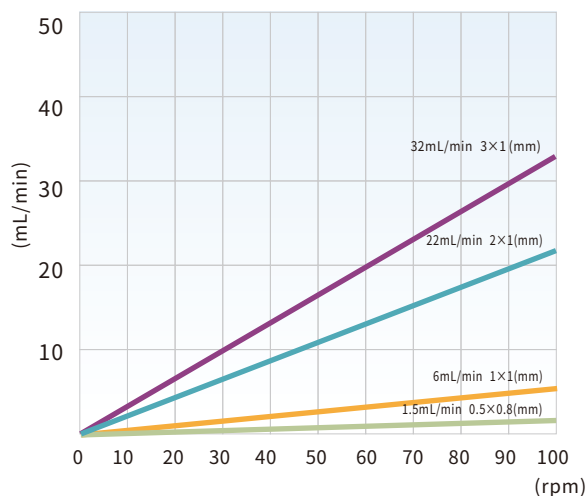

WX10-14

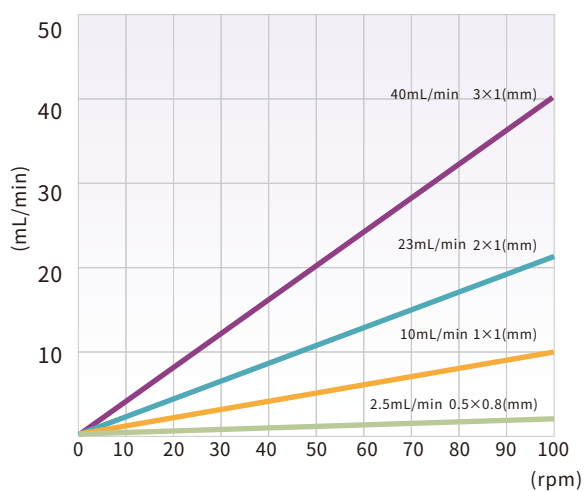

JY10-14

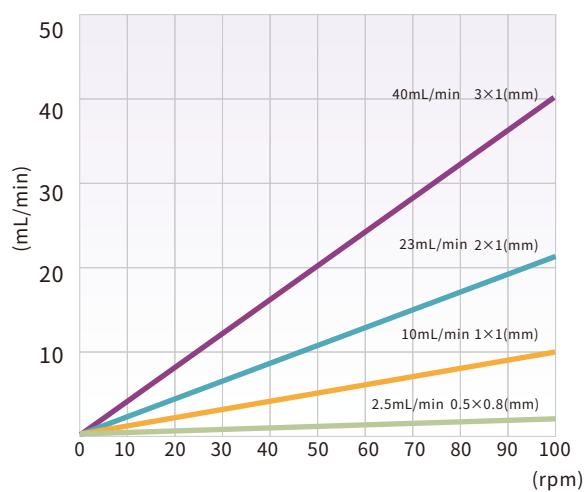

TH15

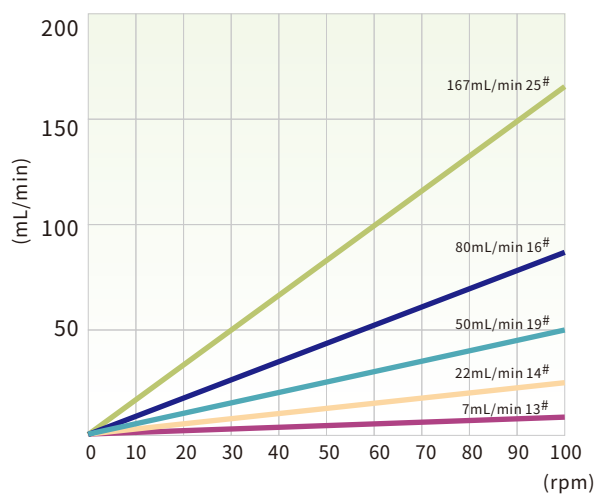

JY15-12

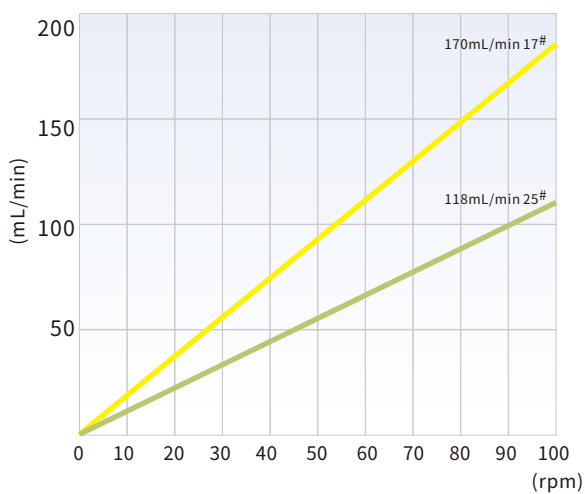

Flow Reference Curve

TUBING

KZ10-24

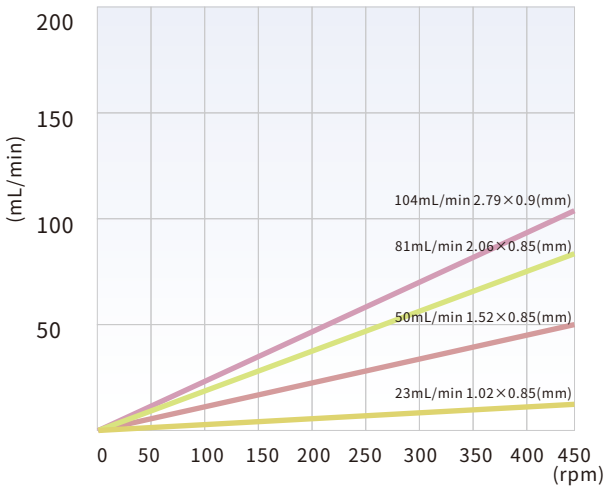

KZ15-14

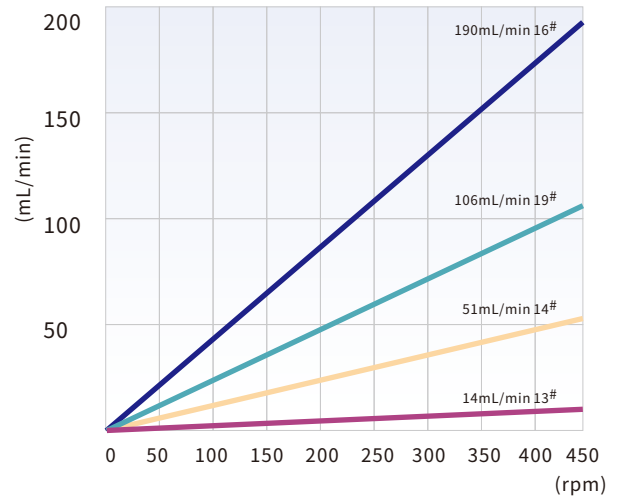

DG15-24

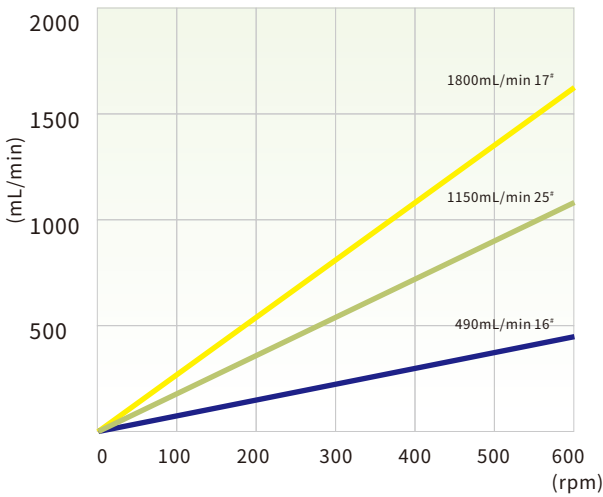

DMD15-13-B

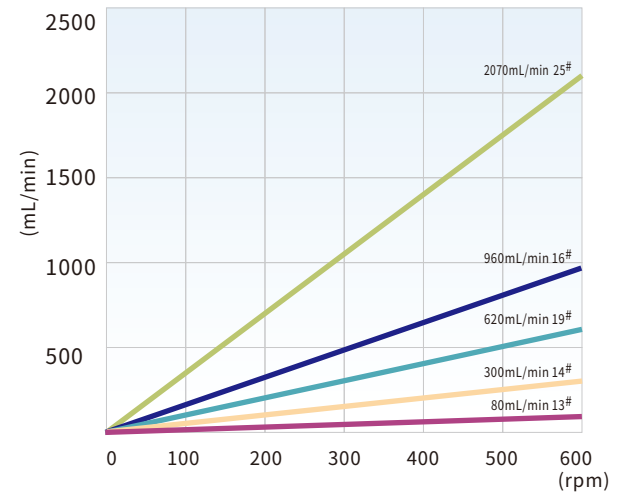

DG15-28

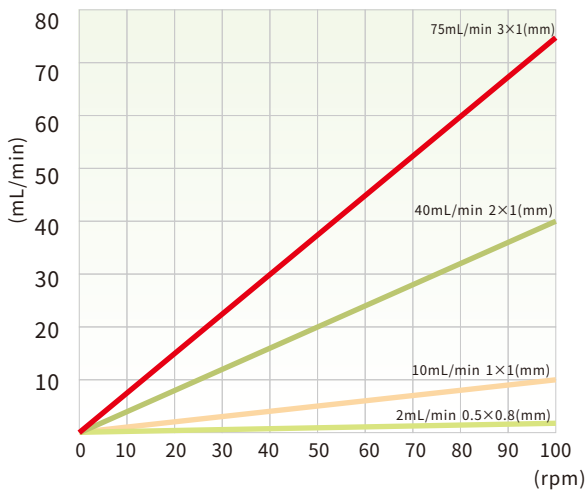

DG15-48

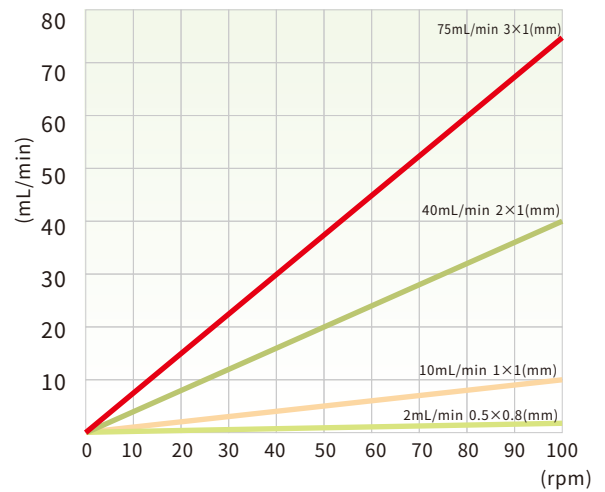

Flow Reference Curve

TUBING

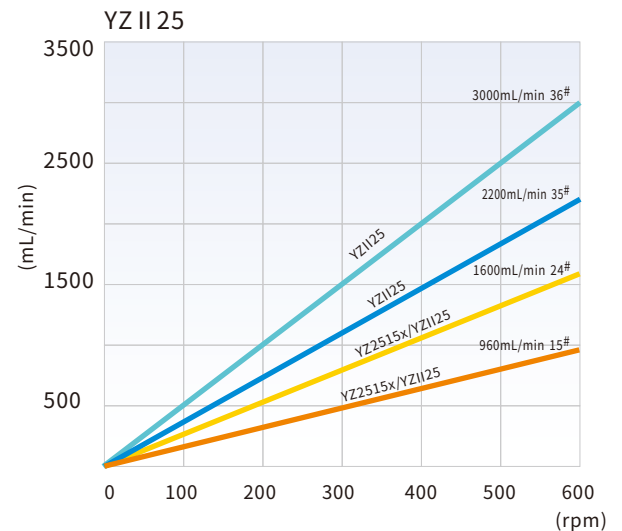
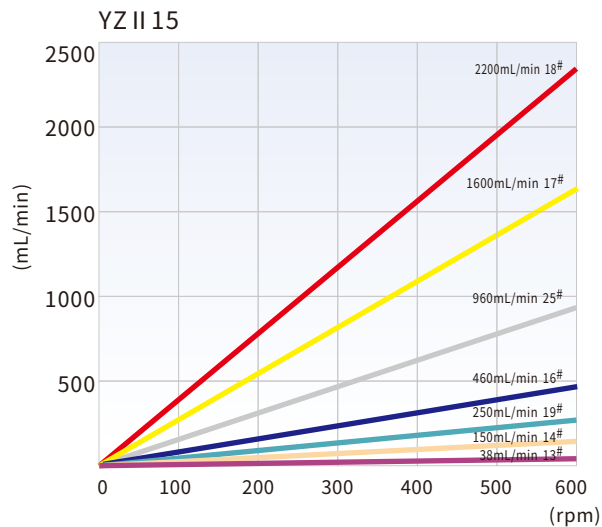
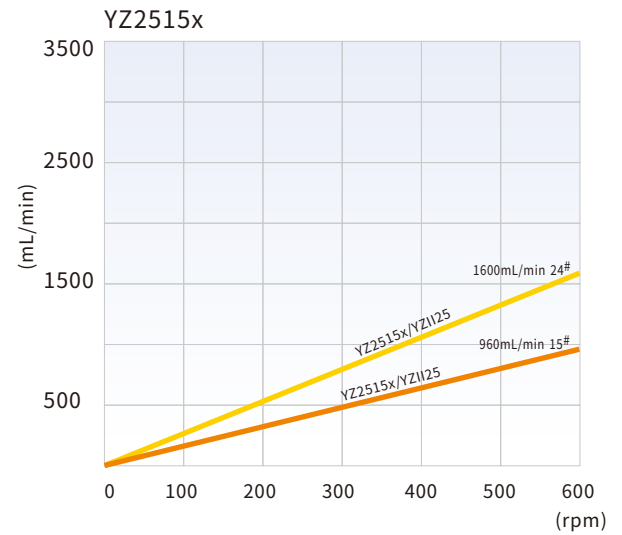
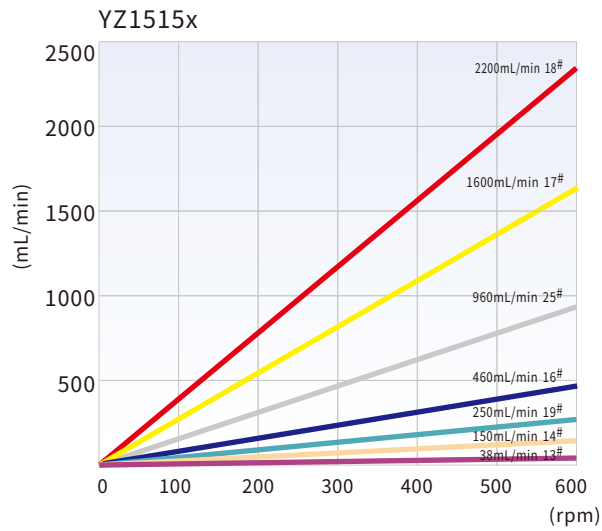
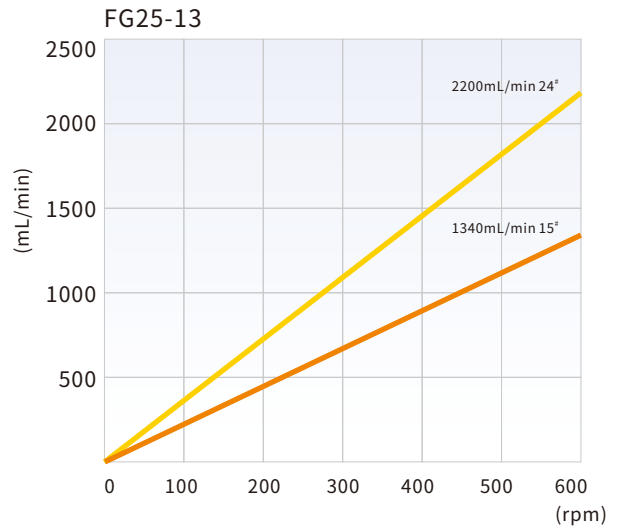
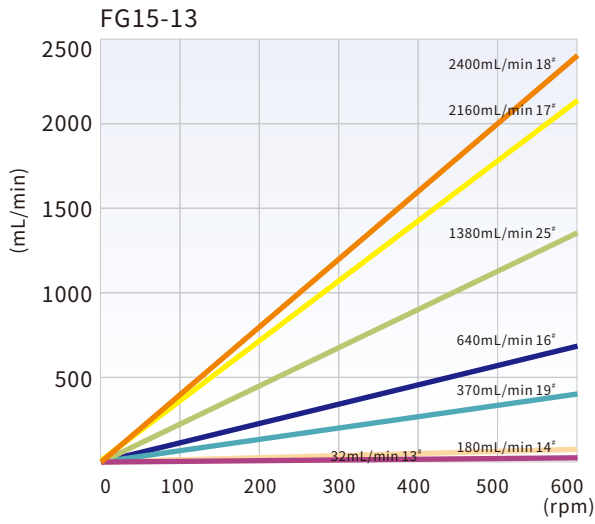

Peristaltic Pump Accessories

Standard External Control Module



ACCESSORY

Dispensing Controller



Peristaltic pump equipped with dispensing controller has dispensing function.

Dispensing time	0-99.99S
Pause time	0-99.99S
Time resolution	0.01S
Work mode	Single or multiple
Internal count range	0-999, count up or count down
External count range	0-9999999, "0" means unlimited cycle
External Start/Stop signal input	Open switch signal
Power-off memory	Return to previous status when powered on
Power supply	AC 220V/5W

Footswitch - JK Series

Multi-work modes and interfaces are available.





Tubing Fitting

Common tubing fitting material:

Natural Polypropylene (Natural PP):
Very good chemical resistance. Temperature range: 0 to 95°C.
Multi-material for tubing fitting are available.

Common tubing fitting type:

Straight, "Y" type, reducing connectors.
There are lots of other tubing fitting type available.

	ID		Tubing			
	(inch)	(mm)				
 Straight Connector	1/16"	1.6	13# 14#			
	1/8"	3.2	16#			
	3/16"	4.8	15# 25#			
	1/4"	6.4	17# 24#			
	3/8"	9.6	18# 35# 36# 73# 86#			
	1/2"	12.7	82# 88#			
	3/4"	19	90#			
	1"	25.4	92#			
 "Y" Type Connector	1/16"	1.6	13# 14#			
	1/8"	3.2	16#			
	3/16"	4.8	15# 25#			
	1/4"	6.4	17# 24#			
	3/8"	9.6	18# 35# 36# 73# 86#			
	1/2"	12.7	82# 88#			
 Reducing Connector	ID1		ID2		Tubing1	Tubing2
	(inch)	(mm)	(inch)	(mm)		
	1/16"	1.6	1/8"	3.2	13# 14#	16#
	1/8"	3.2	3/16"	4.8	16#	15# 25#
	1/8"	3.2	1/4"	6.4	16#	17# 24#
	1/4"	6.4	3/8"	9.6	17# 24#	18# 35# 36# 73# 86#
	3/8"	9.6	1/2"	12.7	18# 35# 36# 73# 86#	82# 88#
	1/2"	12.7	3/4"	19	82# 88#	90#
	1/2"	12.7	1"	25.4	82# 88#	92#



Longer Precision Pump Co.,Ltd.

3rd/4th floor, Building 6B, University Science Park
Baoding National, High-Tech Industrial
Development Zone , Baoding, Hebei, China 071051

Tel: +86-312-3110087

Fax: +86-312-3168553

E-mail: longer@longerpump.com

[Https://www.longerpump.com](https://www.longerpump.com)



* Please determine the product material according to
fluid media and environment.